



TYPICAL

TC131 SERIES

COMPUTER-CONTROLLED CYCLE MACHINE
WITH INPUT FUNCTION

INSTRUCTION BOOK
PARTS CATALOGUE

XI'AN TYPICAL INDUSTRIES CO.,LTD.

Thank you very much for buying a our company's sewing machine. Before using your new machine, please read the safety instructions below and the explanations given in the instruction manual.

With industrial sewing machines, it is normal to carry out work while positioned directly in front of moving parts such as the needle and thread take-up lever, and consequently there is always a danger of injury that can be caused by these parts. Follow the instructions from training personnel and instructors regarding safe and correct operation before operating the machine so that you will know how to use it correctly.



SAFETY INSTRUCTIONS

1. Safety indications and their meanings

This instruction manual and the indications and symbols that are used on the machine itself are provided in order to ensure safe operation of this machine and to prevent accidents and injury to yourself or other people.

The meanings of these indications and symbols are given below.

Indications

	DANGER	The instructions which follow this term indicate situations where failure to follow the instructions will almost certainly result in death or severe injury.
	CAUTION	The instructions which follow this term indicate situations where failure to follow the instructions could cause injury when using the machine or physical damage to equipment and surroundings.

Symbols



This symbol  indicates something that you should be careful of. The picture inside the triangle.) indicates the nature of the caution that must be taken.
(For example, the symbol at left means "beware of injury".)



This symbol  indicates something that you must not do.



This symbol  indicates something that you must do. The picture inside the circle indicates the nature of the thing that must be done.
(For example, the symbol at left means "you must make the ground connection".)

2. Notes on safety

DANGER



Wait at least 5 minutes after turning off the power switch and disconnecting the power cord from the wall outlet before opening the face plate of the control box. Touching areas where high voltages are present can result in severe injury.

CAUTION

Environmental requirements



Use the sewing machine in an area which is free from sources of strong electrical noise such as high-frequency welders.
Sources of strong electrical noise may cause problems with correct operation.



Any fluctuations in the power supply voltage should be within $\pm 10\%$ of the rated voltage for the machine. Voltage fluctuations which are greater than this may cause problems with correct operation.



The power supply capacity should be greater than the requirements for the sewing machine's electrical consumption.
Insufficient power supply capacity may cause problems with correct operation.



The ambient temperature should be within the range of 5°C to 35°C during use.
Temperatures which are lower or higher than this may cause problems with correct operation.



The relative humidity should be within the range of 45% to 85% during use, and no dew formation should occur in any devices.
Excessively dry or humid environments and dew formation may cause problems with correct operation.



Avoid exposure to direct sunlight during use.
Exposure to direct sunlight may cause problems with correct operation.



In the event of an electrical storm, turn off the power and disconnect the power cord from the wall outlet.
Lightning may cause problems with correct operation.

Installation



Machine installation should only be carried out by a qualified technician.



Contact your Brother dealer or a qualified electrician for any electrical work that may need to be done.



The sewing machine weighs approximately 73 kg.
The installation should be carried out by two or more people.



Do not connect the power cord until installation is complete, otherwise the machine may operate if the foot switch is depressed by mistake, which could result in injury.



Hold the machine head with both hands when tilting it back or returning it to its original position.
Furthermore, after tilting back the machine head, do not push the face plate side or the pulley side from above, as this could cause the machine head to topple over, which may result in personal injury or damage to the machine.



Be sure to connect the ground. If the ground connection is not secure, you run a high risk of receiving a serious electric shock, and problems with correct operation may also occur.



All cords should be secured at least 25 mm away from any moving parts. Furthermore, do not excessively bend the cords or secure them too firmly with staples, otherwise there is the danger that fire or electric shocks could occur.



Install the safety covers to the machine head and motor.



If using a work table which has casters, the casters should be secured in such a way so that they cannot move.











Be sure to wear protective goggles and gloves when handling the lubricating oil and grease, so that they do not get into your eyes or onto your skin, otherwise inflammation can result.

Furthermore, do not drink the oil or eat the grease under any circumstances, as they can cause vomiting and diarrhoea.



Keep the oil out of the reach of children.

CAUTION









Sewing

-  This sewing machine should only be used by operators who have received the necessary training in safe use beforehand.
-  The sewing machine should not be used for any applications other than sewing.
-  Be sure to wear protective goggles when using the machine.
If goggles are not worn, there is the danger that if a needle breaks, parts of the broken needle may enter your eyes and injury may result.
-  Turn off the power switch at the following times, otherwise the machine may operate if the foot switch is depressed by mistake, which could result in injury.
When threading the needle
When replacing the needle and bobbin
When not using the machine and when leaving the machine unattended
-  If using a work table which has casters, the casters should be secured in such a way so that they cannot move.
-  Attach all safety devices before using the sewing machine. If the machine is used without these devices attached, injury may result.
-  Do not touch any of the moving parts or press any objects against the machine while sewing, as this may result in personal injury or damage to the machine.
-  If an error occurs in machine operation, or if abnormal noises or smells are noticed, immediately turn off the power switch. Then contact your nearest Brother dealer or a qualified technician.
-  If the machine develops a problem, contact your nearest Brother dealer or a qualified technician.

Cleaning

-  Turn off the power switch before carrying out cleaning, otherwise the machine may operate if the foot switch is depressed by mistake, which could result in injury.
-  Be sure to wear protective goggles and gloves when handling the lubricating oil and grease, so that they do not get into your eyes or onto your skin, otherwise inflammation can result.
Furthermore, do not drink the oil or eat the grease under any circumstances, as they can cause vomiting and diarrhoea.
Keep the oil out of the reach of children.

Maintenance and inspection

-  Maintenance and inspection of the sewing machine should only be carried out by a qualified technician.
-  Ask your Brother dealer or a qualified electrician to carry out any maintenance and inspection of the electrical system.
-  Turn off the power switch and disconnect the power cord from the wall outlet at the following times, otherwise the machine may operate if the foot switch is depressed by mistake, which could result in injury.
When carrying out inspection, adjustment and maintenance
When replacing consumable parts such as the rotary hook
-  If the power switch needs to be left on when carrying out some adjustment, be extremely careful to observe all safety precautions.
-  Hold the machine head with both hands when tilting it back or returning it to its original position.
Furthermore, after tilting back the machine head, do not push the face plate side or the pulley side from above, as this could cause the machine head to topple over, which may result in personal injury or damage to the machine.
-  Use only the proper replacement parts as specified by our company's.
-  If any safety devices have been removed, be absolutely sure to re-install them to their original positions and check that they operate correctly before using the machine.
-  Any problems in machine operation which result from unauthorized modifications to the machine will not be covered by the warranty.

3.Warning labels

The following warning labels appear on the sewing machine.

Please follow the instructions on the labels at all times when using the machine.If the labels have been removed or are difficult to read, please contact your nearest dealer.

1



2



Be sure to connect the ground. If the ground connection is not secure, you run a high risk of receiving a serious electric shock, and problems with correct operation may also occur.

3



Direction of operation

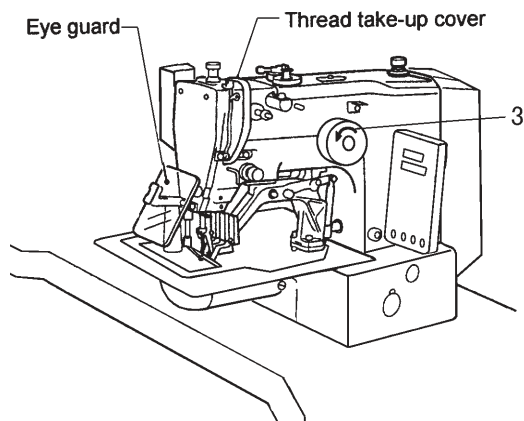

Safety devices:

- (A)Eye guard
- (B)Tension release solenoid cover
- (C)Thread take-up cover
- (D)Back cover,etc.
- (E)Frame side cover

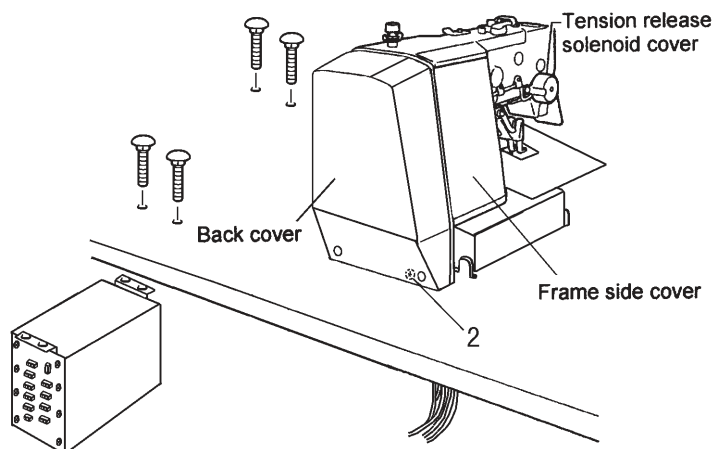

1. NAMES OF MAJOR PARTS

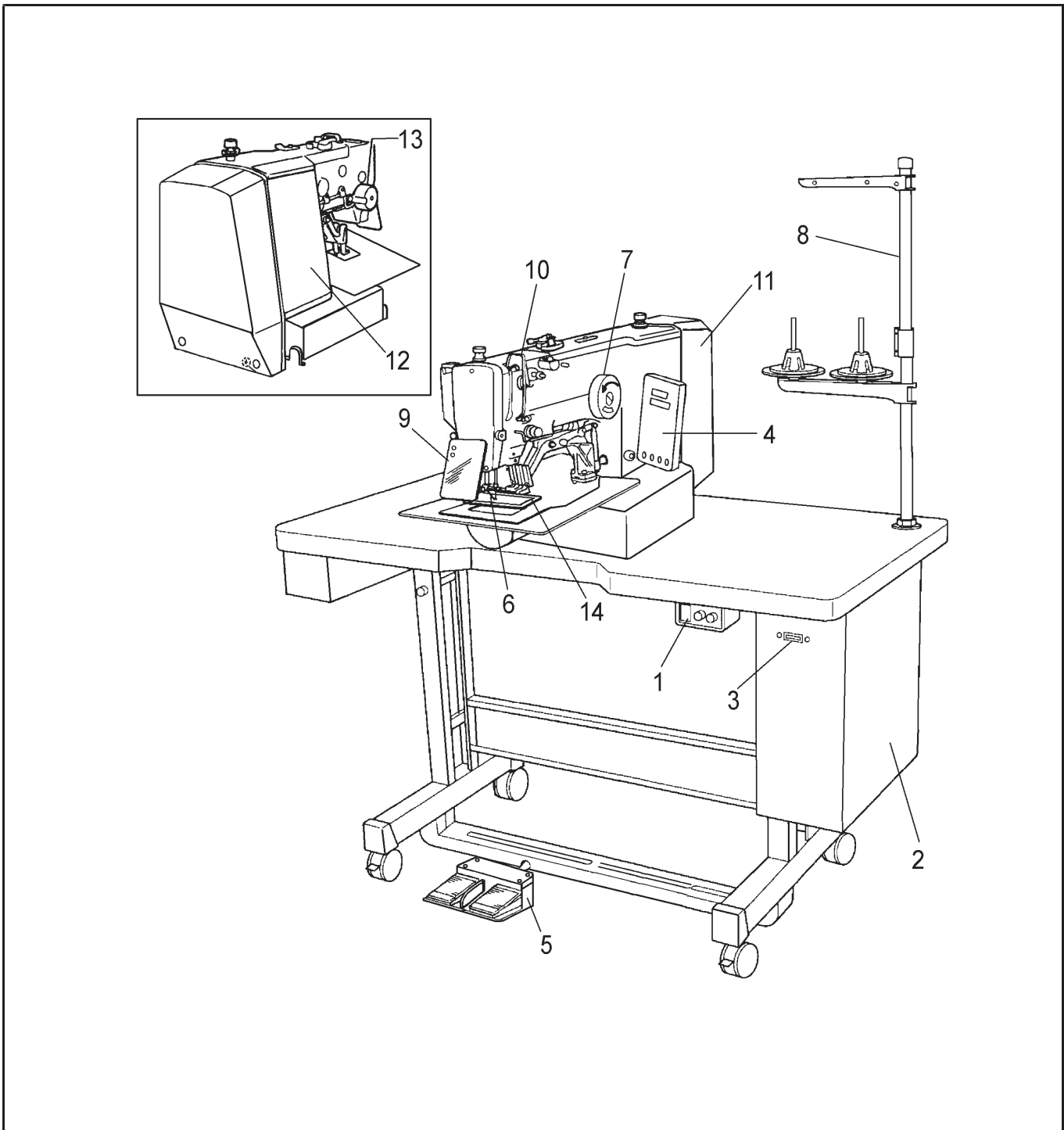









- (1) Power switch
- (2) Control box
- (3) SD slot
- (4) Operation panel
- (5) Switch of pedal
- (6) Middle presser foot
- (7) Pulley
- (8) Cotton stand

- Safety devices**
- (9) Eye guard
 - (10) Thread take-up cover
 - (11) Back cover
 - (12) Frame side cover
 - (13) Tension release solenoid cover
 - (14) Presser frame

2. SPECIFICATIONS

	TC131-0705
Stitch formation	Single needle lock stitch
Maximum sewing speed	2700rpm
Pattern size(X×Y)	70×50mm
Feed mechanism	Y-0 intermittent feed mechanism (pulse-motor driven mechanism)
Stitch length	0.1-12.7mm
Number of stitches	Variable (Refer to "Program List" for details on the number of stitches for sewing patterns that are already preset.)
Maximum stitch number	400,000 stitches
Work clamp lifter	Pulse-motor driven mechanism
lift of presser frame	17mm max.
stroke of middle presser foot	5mm
Rotary hook	Shuttle hook
Wiper device	Standard equipment
Thread trimmer device	Standard equipment
lift of middle presser foot	16mm
Data storage method	Flash memory (Any sewing pattern can be added using SD card)
Number of stored data	3 sewing patterns are set already
Motor	AC servo motor 450 W
Power source	220V+10% 50HZ(others are optional)

3. INSTALLATION

 CAUTION	
<p> Machine installation should only be carried out by a qualified technician.</p> <p> Contact your Brother dealer or a qualified electrician for any electrical work that may need to be done. The sewing machine head weighs approximately 56 kg. The installation should be carried out by two or more people.</p> <p> Do not connect the power cord until installation is complete, otherwise the machine may operate if the foot switch is depressed by mistake, which could result in injury.</p> <p> Hold the machine head with both hands when tilting it back or returning it to its original position. Furthermore, after tilting back the machine head, do not push the face plate side or the pulley side from above, as this could cause the machine head to topple over, which may result in personal injury or damage to the machine.</p>	<p> All cords should be secured at least 25 mm away from any moving parts. Furthermore, do not excessively bend the cable or secure it too firmly staples, otherwise there is the danger that fire or electric shocks could occur.</p> <p> Be sure to connect the ground: If the ground connection is not secure, you run the risk of receiving a serious electric shock, and problems with correct operation may also occur.</p> <p> Install the safety covers to the machine head and motor.</p>

3-1. Installing the cotton stand

(1) Cotton stand

Note:

Securely tighten the nut (4) so that the two rubber cushions (2) and the washer (3) are securely clamped and so that the cotton stand (1) does not move.

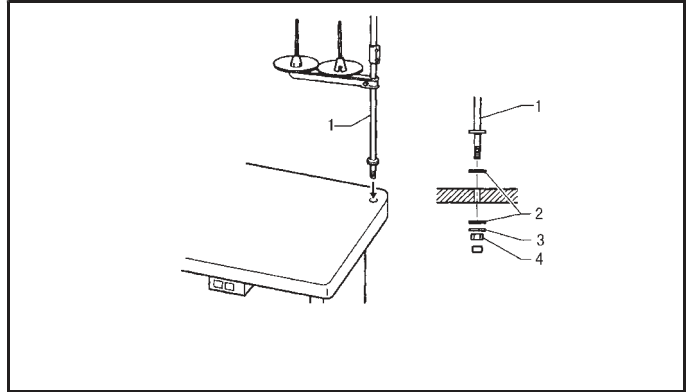

3-2. Lubrication

The sewing machine should always be lubricated and the oil supply replenished before it is used for the first time, and also after long periods of non-use.

Use only the lubricating oil specified by our company's.

1. Fill the oil tank with oil.

Note

Fill the machine with oil when the oil level is down to about one-third full in the oil sight glass. If the oil drops below this level, there is the danger that the machine may seize during operation.

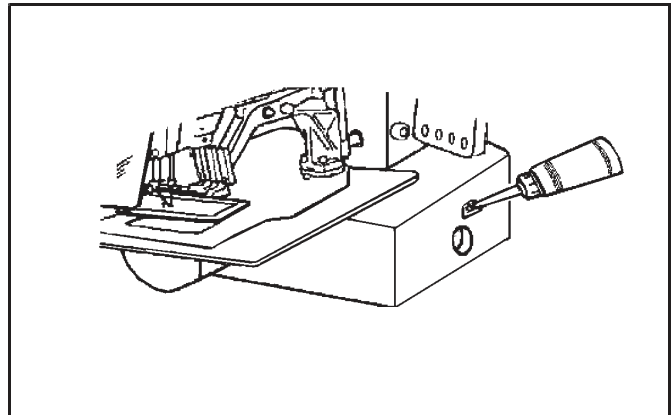

2. Pour oil in through the two holes (1) of the shuttle race base assembly so that the felt is lightly moistened.

Note:

If there is no more oil on the felt of the shuttle race base assembly, problems with sewing may result.

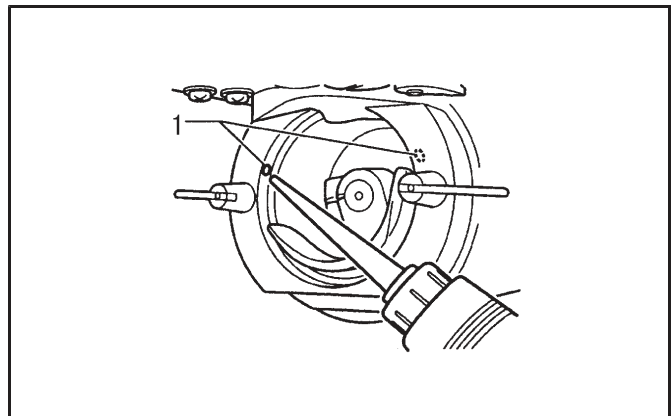

3. If using the liquid cooling tank (2), fill it with silicon oil (100 mm² /s).

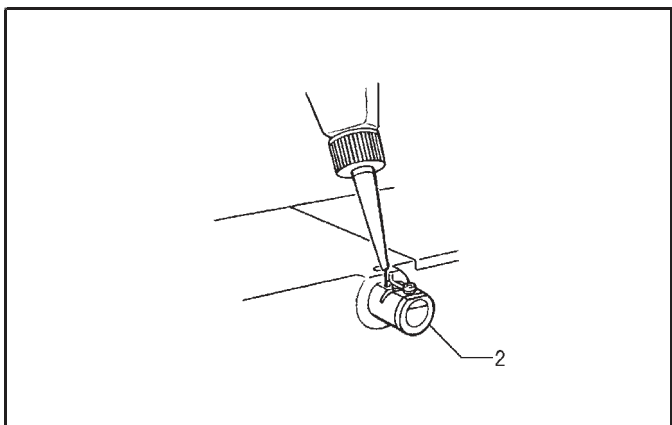

3-3.Starting up

1.Turn on the power switch.

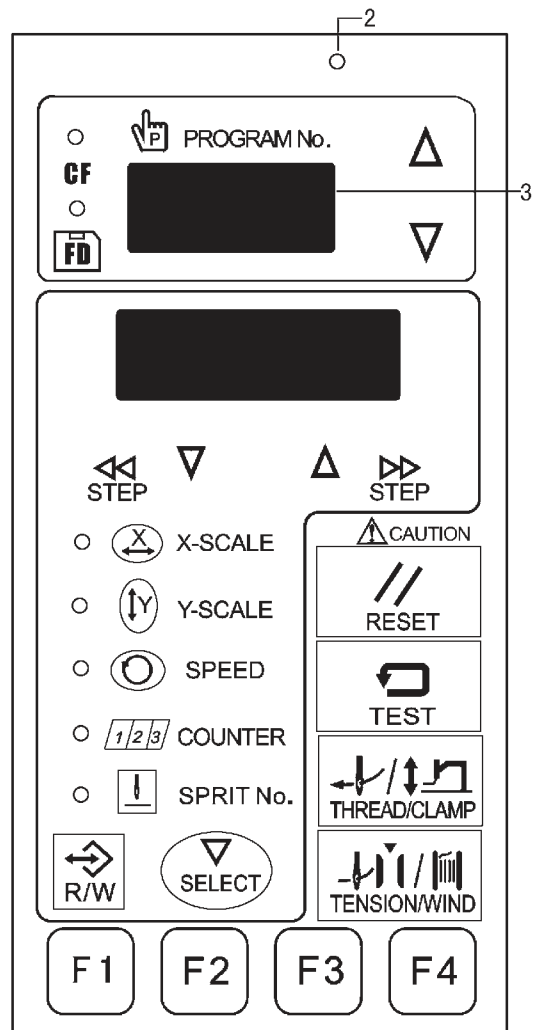

2.Tread pedal 2 to position 1 could select pattern , tread pedal 1 to position 1 presser foot lift

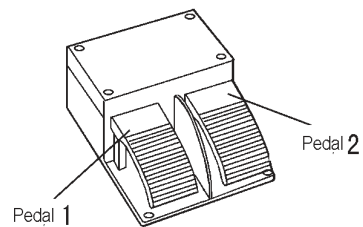
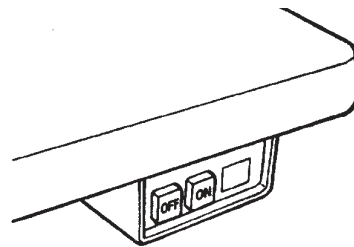

4. PREPARATION BEFORE SEWING

4-1. Installing the needle



Turn off the power switch before installing the needle, otherwise the machine may operate if the foot switch is depressed by mistake, which could result in injury.

1. Loosen the set screw (1).
2. Insert the needle (2) in a straight line as far as it will go, making sure that the long groove on the needle is at the front, and then securely tighten the screw (1).

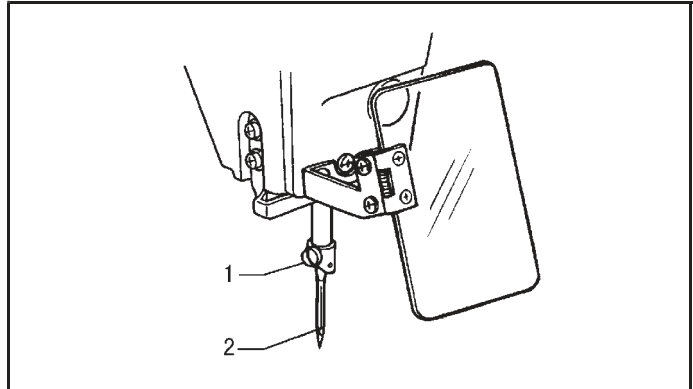

4-2. Threading the upper thread

Thread the upper thread correctly as shown in the illustration below.

* When using threading mode for threading, the tension discs (1) will open so that the thread can be threaded more easily.

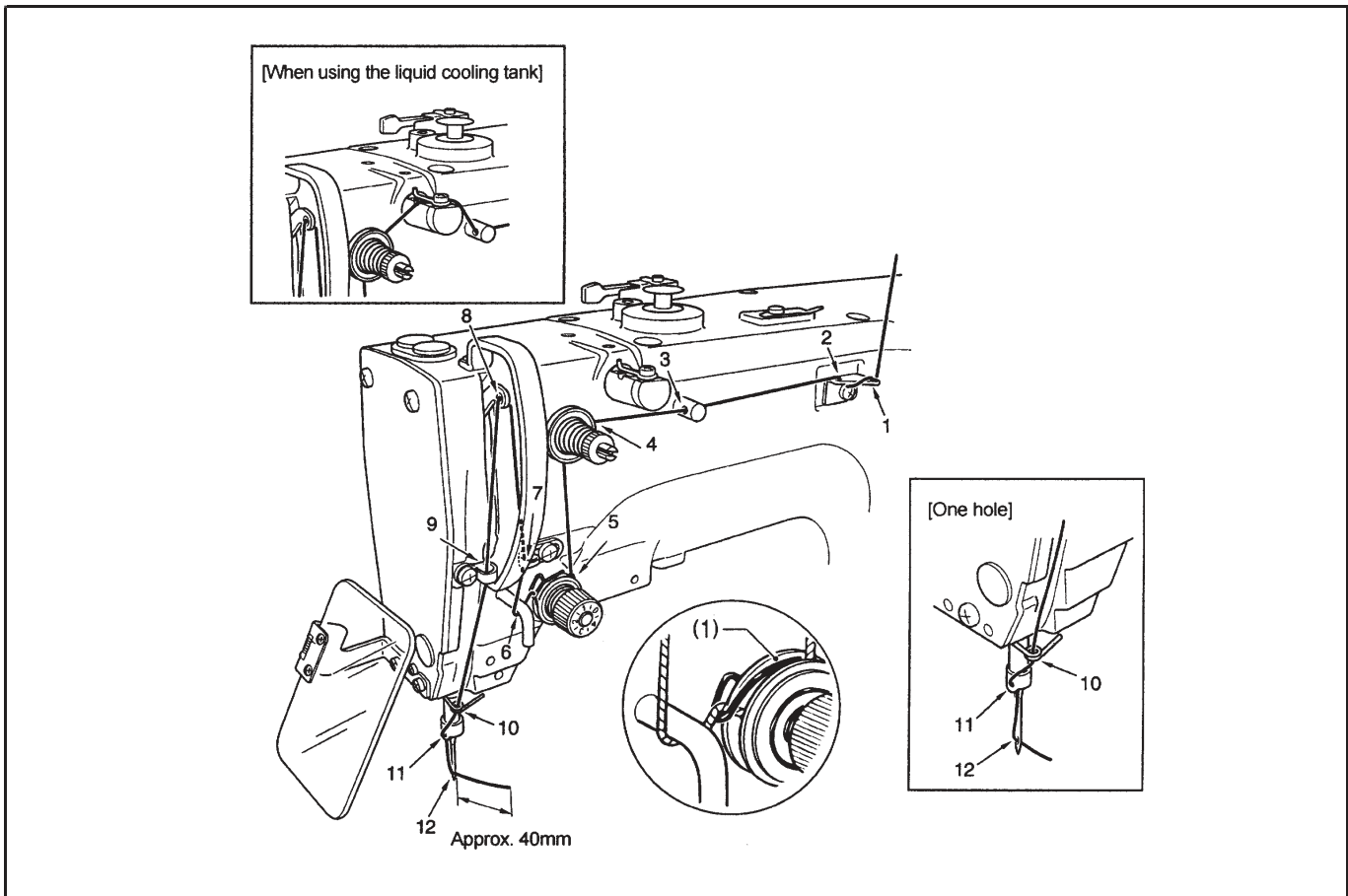

<Threading mode>

Threading mode is safe because the sewing machine will not start even when the foot switch is depressed.

1. Turn on the power switch.

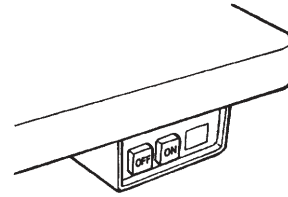

- 2. ● The work clamp /button clamp will lower
- The tension discs will open.



Press the THREAD/CLAMP key.

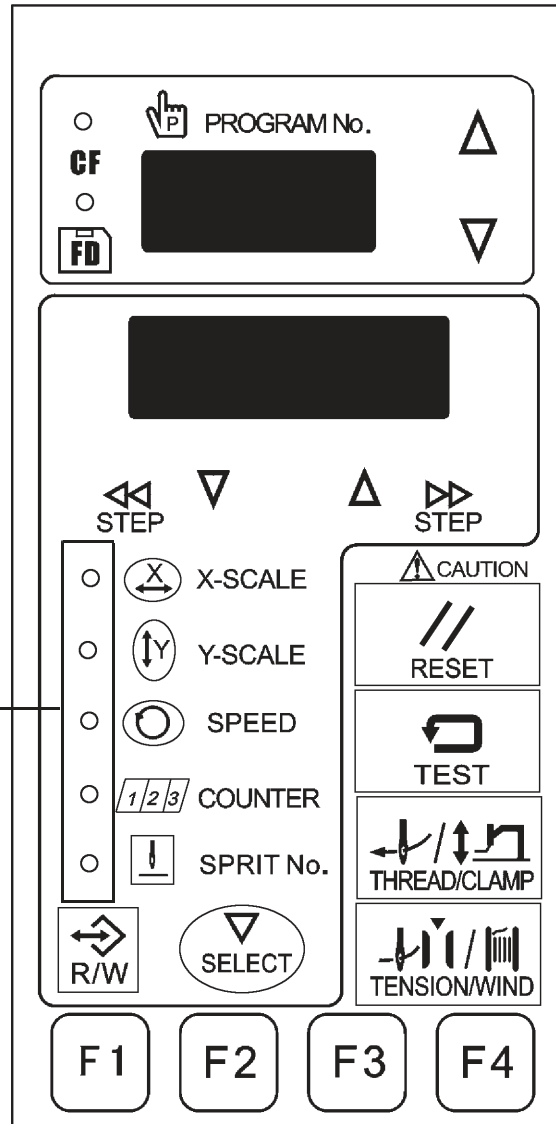

All indicators switch off
 THREAD/CLAMP indicator lights
 Menu indicators switch off

3. Threading the thread.

- When 5 minutes have passed, the buzzer will sound and the tension discs will close.

4. Ending threading mode

Press the THREAD/CLAMP key.

- The work clamp/button clamp will return to where it was before threading mode was started.



THREAD/CLAMP indicator switches off

4-3. Winding the lower thread



CAUTION



Do not touch any of the moving parts or press any objects against the machine while winding the lower thread, as this may result in personal injury or damage to the machine.

1. Place the bobbin onto the bobbin winder shaft (1).
2. Thread the thread as shown in the illustration, wind the thread around the bobbin several times, and then press the bobbin presser arm (2).
3. Turn on the power switch.
4. Tread pedal 1 to position 1, could check up origin position
5. Make sure needle will not strike presser foot then push button TENSION/WIND (3) and tread pedal 2 to position 1 at the same time.
6. When machine start working release button TENSION/WIND (3), keep on treading pedal 2 until thread winding finished. If release pedal during thread winding, please push button TENSION/WIND (3) once again and tread pedal 2 thread winding will start again.
7. When thread winding reaches the regulated amount (80-90% of bobbin's outside diameter), it should be stopped. Bobbin holder will come back automatically; thread pedal 2 to position 0. Thread winding finished.
8. Remove the bobbin, hook the thread onto the knife (4), and then pull the bobbin in the direction of the arrow to cut the thread.

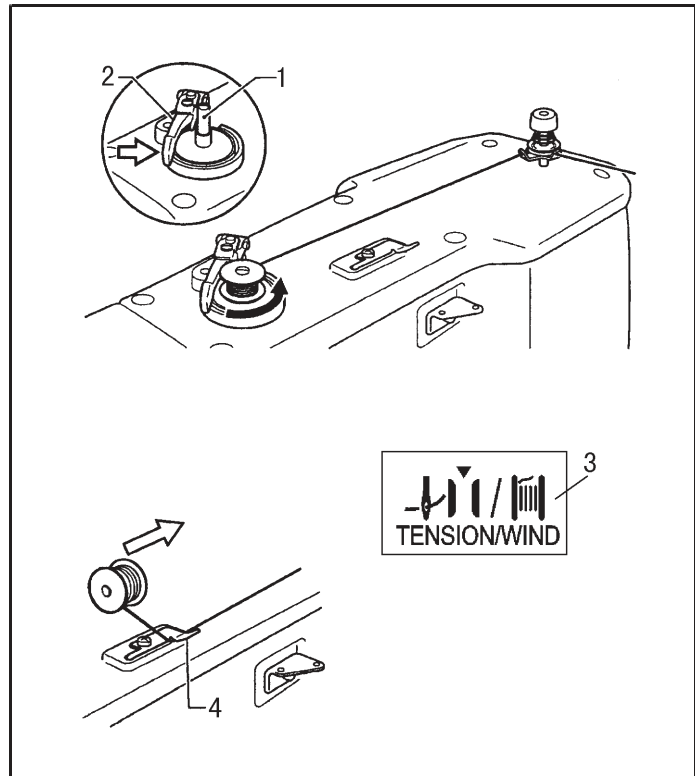

Adjusting the bobbin winding amount

Loosen the screw (5) and move the bobbin presser (6).

If the thread winds onto the bobbin unevenly

Loosen the set screw (7) and move the bobbin winder tension assembly (8) up and down to adjust.

* For case A, move the bobbin winder tension assembly (8) down, and for case B, move it upward.

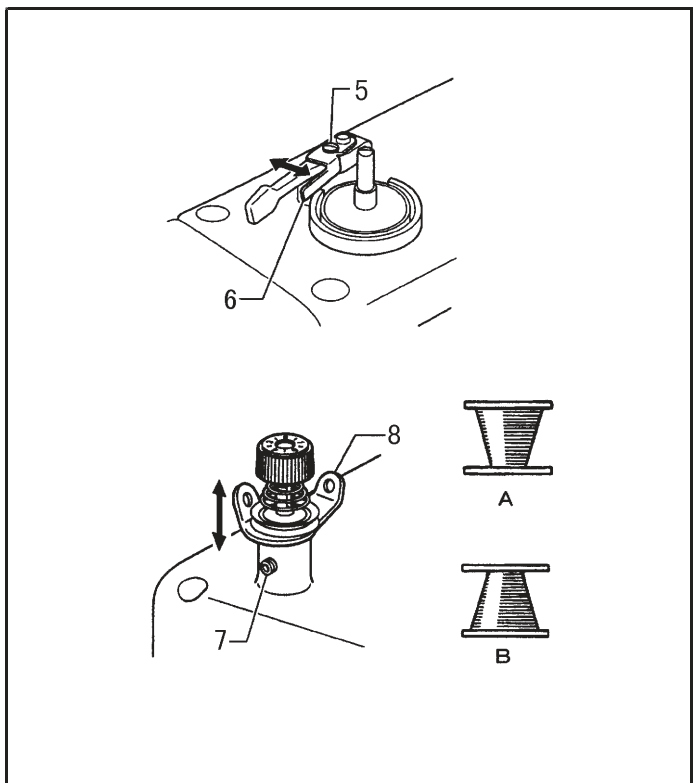

4-4. Installing the bobbin case



CAUTION



Turn off the power switch before installing the bobbin case, otherwise the machine may operate if the foot switch is depressed by mistake, which could result in injury.

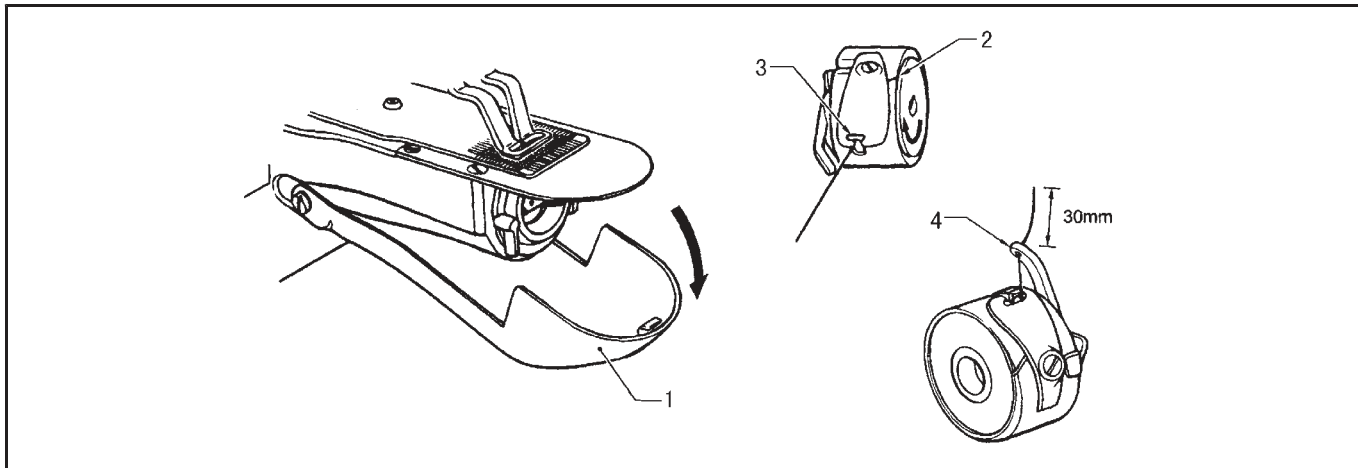

1. Pull the shuttle race cover (1) downward to open it.
2. While holding the bobbin so that the thread winds to the right, insert the bobbin into the bobbin case.
3. Pass the thread through the slot (2) and pull it out from the thread hole (3).
4. Check that the bobbin turns in the direction of the arrow when the thread is pulled.
5. Pass the thread through the lever thread hole (4), and then pull out approximately 30 mm of thread.
6. Hold the latch on the bobbin case and insert the bobbin case into the rotary hook.

5. SEWING



CAUTION



Turn off the power switch at the following times, otherwise the machine may operate if the foot switch is depressed by mistake, which could result in injury.

- When threading the needle
- When replacing the needle and bobbin
- When not using the machine and when leaving the machine unattended



Do not touch any of the moving parts or press any objects against the machine while sewing, as this may result in personal injury or damage to the machine.

1. Turn on the power switch.
2. Press the Δ or ∇ key (1) to select the number for the program to be sewn.
3. Tread pedal 2 to position 1, select program, tread pedal 1 to position 1, presser foot lift
4. Put fabric under presser foot 2
5. Tread panel 1 to position 2 presser foot comes down.
6. Tread pedal to position 1 machine start working.

4. Put fabric under presser foot 2
5. Tread panel 1 to position 2 presser foot comes down.
6. Tread pedal to position 1 machine start working.

7. Once sewing is completed and the thread has been trimmed, the work clamp (2) will rise.

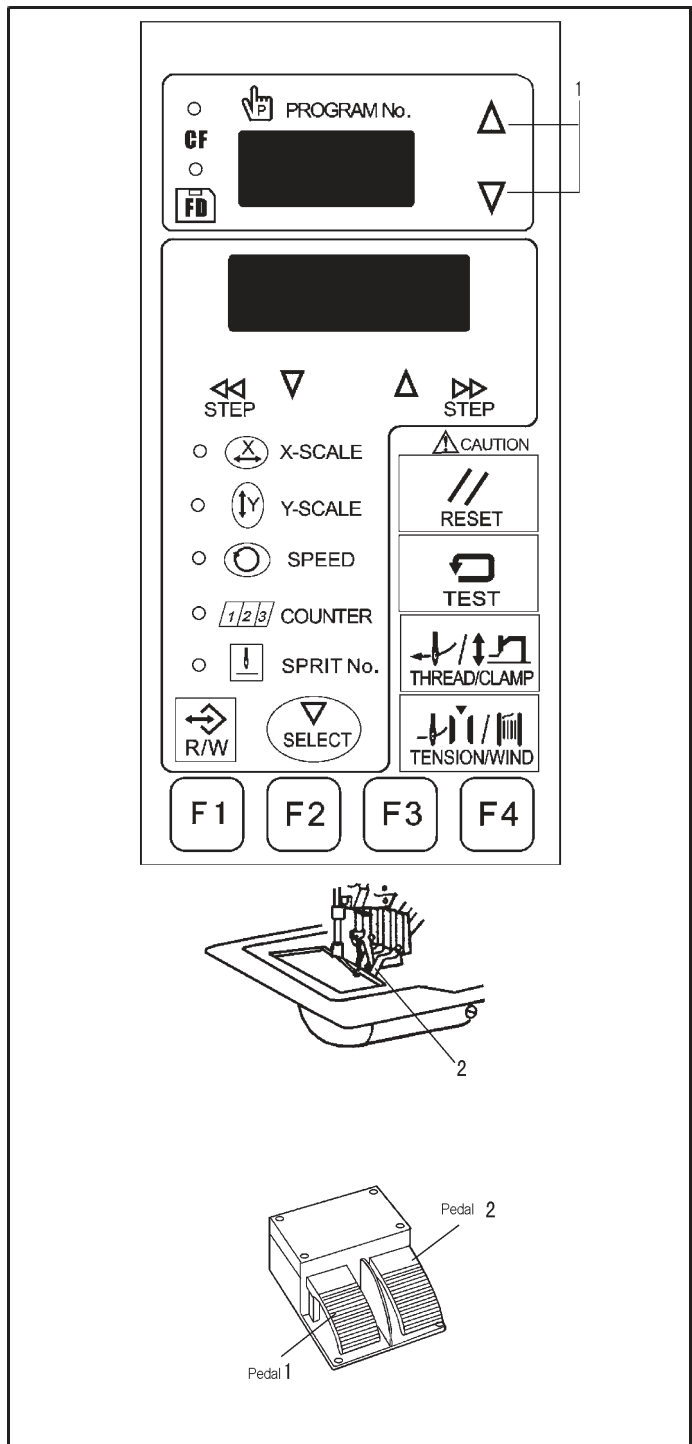

6.ADJUSTING

6-1 Thread tension

6-1-1 Lower thread tension

Adjust the thread tension to the weakest possible tension by turning the thread tension nut (1) until the bobbin case will not drop by its own weight while the thread end coming out of the bobbin case is held.

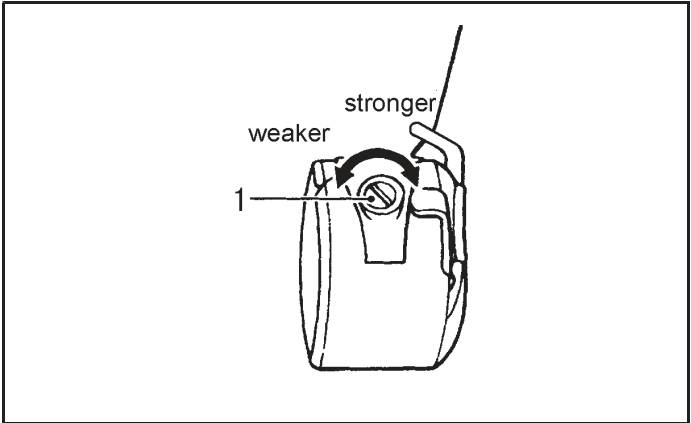

6-1-2. Upper thread tension

Turn the tension nut (1)(main tension) to adjust the tension as appropriate for the material being sewn. Furthermore, turn the tension nut (2) (sub-tension) to adjust the remaining length of upper thread to 35 – 40 mm, when the thread take-up lever is not used.

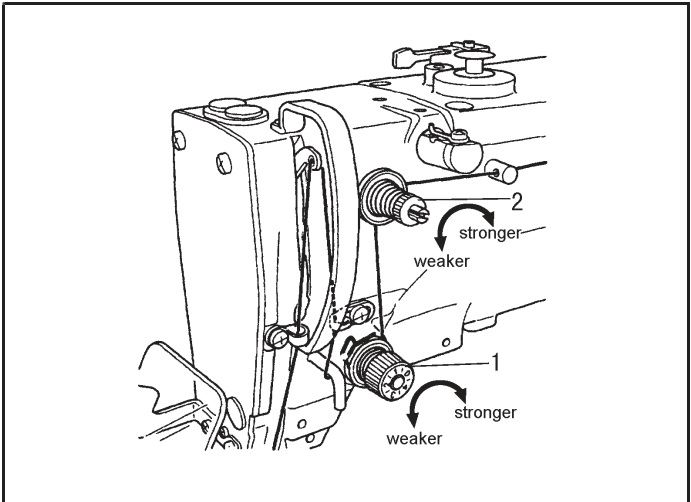

Reference thread tension

Use	TC131
Upper thread	#30 or equivalent
Lower thread	#50 or equivalent
Upper thread tension (N)	1.6-2.0
Lower thread tension (N)	0.2-0.3
Pre-tension (N)	0.05-0.3
Needle	DP×17 #19

Note: The thread may break due to heat under some sewing conditions. If this happens, reduce the sewing speed, or use the liquid cooling tank.

7. MAINTENANCE

7-1. Cleaning the rotary hook

1. Pull the shuttle race cover downward to open it, and then remove the bobbin case.
2. Open the setting claw (1) in the direction indicated by the arrow, and then remove the shuttle race base (2) and the shuttle hook (3).
3. Clean all the dust and thread ends from around the driver (4), the top of the rotary hook thread guide and the shuttle race.

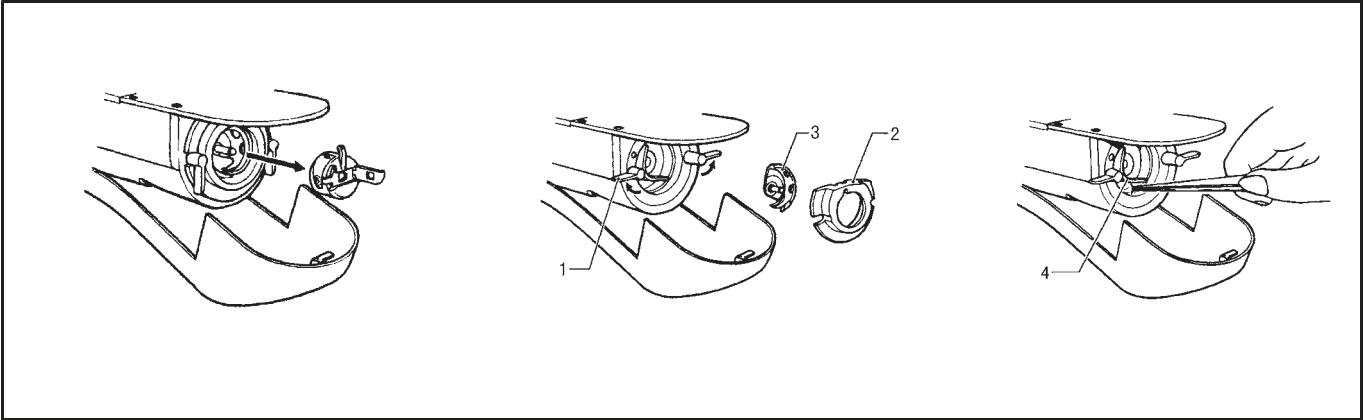

7-2. Draining the oil

1. Remove and empty the waste oil container (1) whenever it is full.
2. After emptying the waste oil container (1), screw it back into its original position.

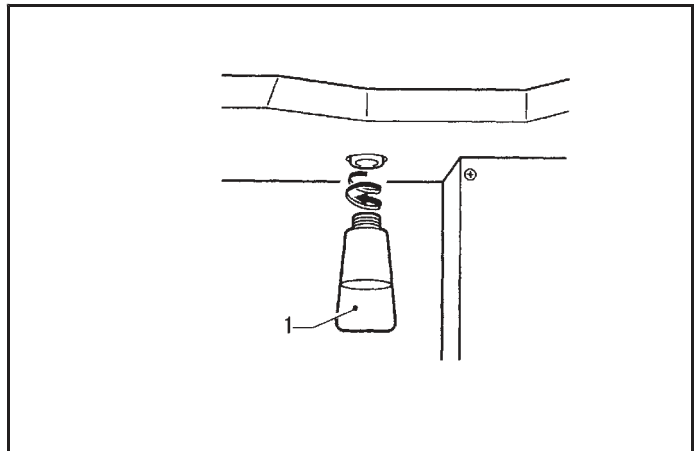

7-3. Cleaning the eye guard

Wipe the eye guard clean with a soft cloth.

Note:

Do not use solvents such as kerosene or thinner to clean the eye guard.

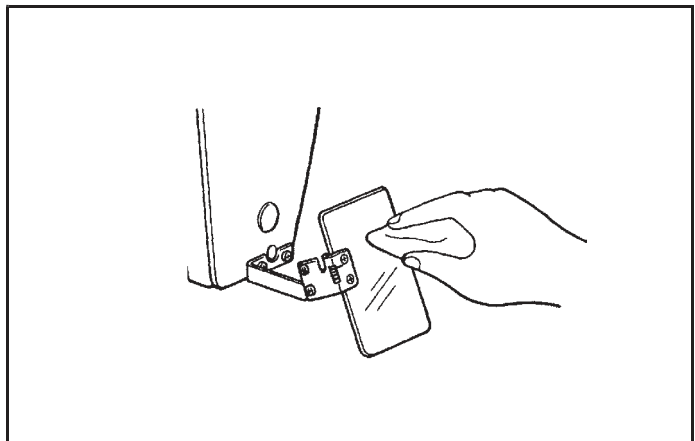

7-4. Checking the needle

Always check that the tip of the needle is not broken and also the needle is not bent before starting sewing.

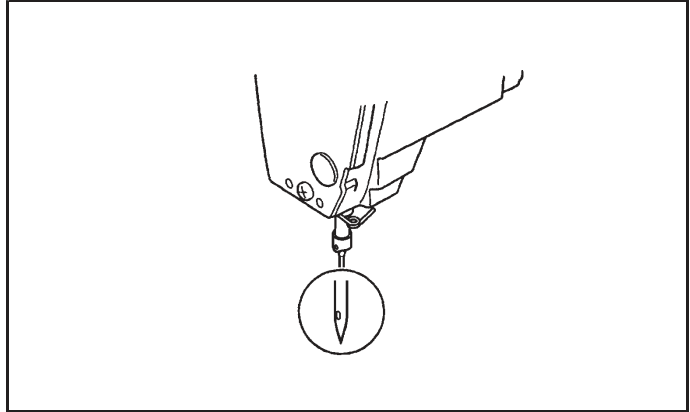

7-5. Lubrication

Carry out the lubrication referring to "3-12 lubrication"

7-6. Applying grease

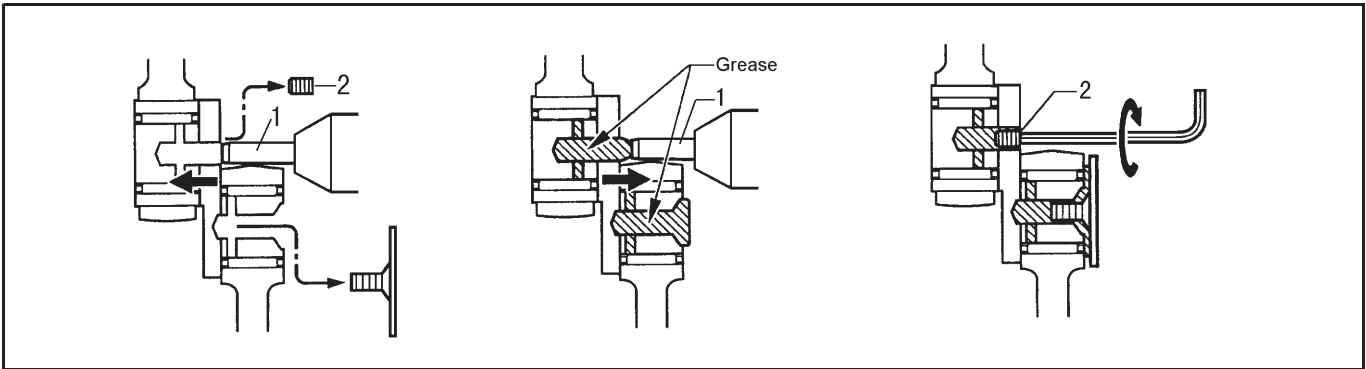

1. Turn off the power switch.
2. Remove the screw (2). (Refer to the separate page for greasing locations.)
3. While turning the machine pulley by hand to move the needle bar up and down, apply grease to each hole until the grease overflows slightly.
4. Tighten the screw (2) to push in the grease.
5. Turn the machine pulley by hand to move the needle bar up and down several times in order to disperse the grease.
6. Use a cloth to wipe away any excess grease from around the screw (2).

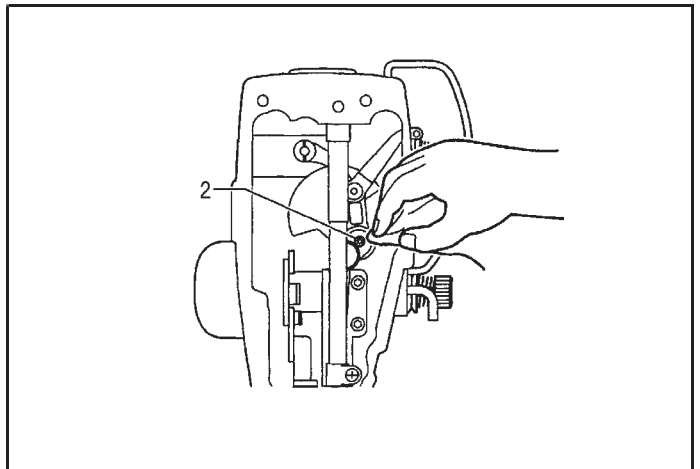

Note:

- Once the grease tube has been opened, remove the nozzle from the tube, attach the cap securely and store the tube in a cool dark place.
 - The grease should be used as quickly as possible.
 - When using the grease again, remove any old grease from inside the nozzle first
- (Store the tube away carefully once the tube has been opened, otherwise the grease remaining inside the tube may deteriorate, and this may affect its lubricating performance.)

Trouble shooting

Trouble	Cause	Check point	Remedy
Thread breaks	<p>Surface thread tension is too strong</p> <p>needle is not properly installed</p> <p>Thread is too big thick for the needle</p> <p>Bottom thread tension is too strong</p>	<p>Surface thread tension</p> <p>Needle direction</p> <p>Needle and Thread</p> <p>Bottom thread tension</p>	<p>Adjust the tension</p> <p>Needle slot face the front</p> <p>Choose the needle and thread</p> <p>Adjust the tension</p>
Thread slips out of needle at first stitch	<p>Space between needle and hook is too big</p> <p>Needle enter too much into the hook</p> <p>Needle bent</p> <p>Needle installed incorrectly</p>	<p>Space between needle and hook</p> <p>Space between needle and hook</p> <p>Needle bent</p> <p>Needle direction</p>	<p>Adjust the Space between needle and hook</p> <p>Adjust the Space between needle and hook</p> <p>Choose the needle and thread and change the needle</p> <p>Needle slot face the front</p>
Needle breaks	<p>Needle touch the hook</p> <p>Needle bent</p> <p>Wrong sewing</p> <p>Swing hook too high</p>	<p>Space between needle and hook</p> <p>Needle bent</p> <p>needle and fabric not in synchronization</p> <p>Height of the Swing hook</p>	<p>Adjust the Space between needle and hook</p> <p>Choose the needle and thread and change the needle</p> <p>Adjust the needle and fabric in synchronization</p> <p>Adjust the Height of the Swing hook</p>

Trouble shooting

Trouble	Cause	Check point	Remedy
Thread not trimmed	<p>fixed knife blunt thread cutting spring loose, moving knife cannot move in place moving knife cannot turn Surface thread Last stitch skip, moving knife cannot turn Surface thread moving knife wrong position</p>	<p>Fix knife blade thread cutting spring tension hook guide line position skip last stitch moving knife position</p>	<p>changing the moving knife changing the thread cutting spring put the hook guide line in same line with the hook Turn to the skip stitch adjust the moving knife position</p>
Thread ensnared	<p>picking spring too loose hook guide line not spread the thread</p>	<p>picking spring tension hook guide line position</p>	<p>adjust the picking spring tension and height put the hook guide line in same line with the hook</p>
Thread tension poor	<p>Surface thread tension too weak Bottom thread tension too weak</p>	<p>Surface thread tension Bottom thread tension</p>	<p>adjust the tension adjust the tension</p>
Preeser foot does not rise	<p>Footlifter motor problem Footlifter cam not Synchronization</p>	<p>Motor gear Footlifter cam Synchronization position</p>	<p>change motor Adjust Footlifter cam Synchronization position</p>

1. Machine body

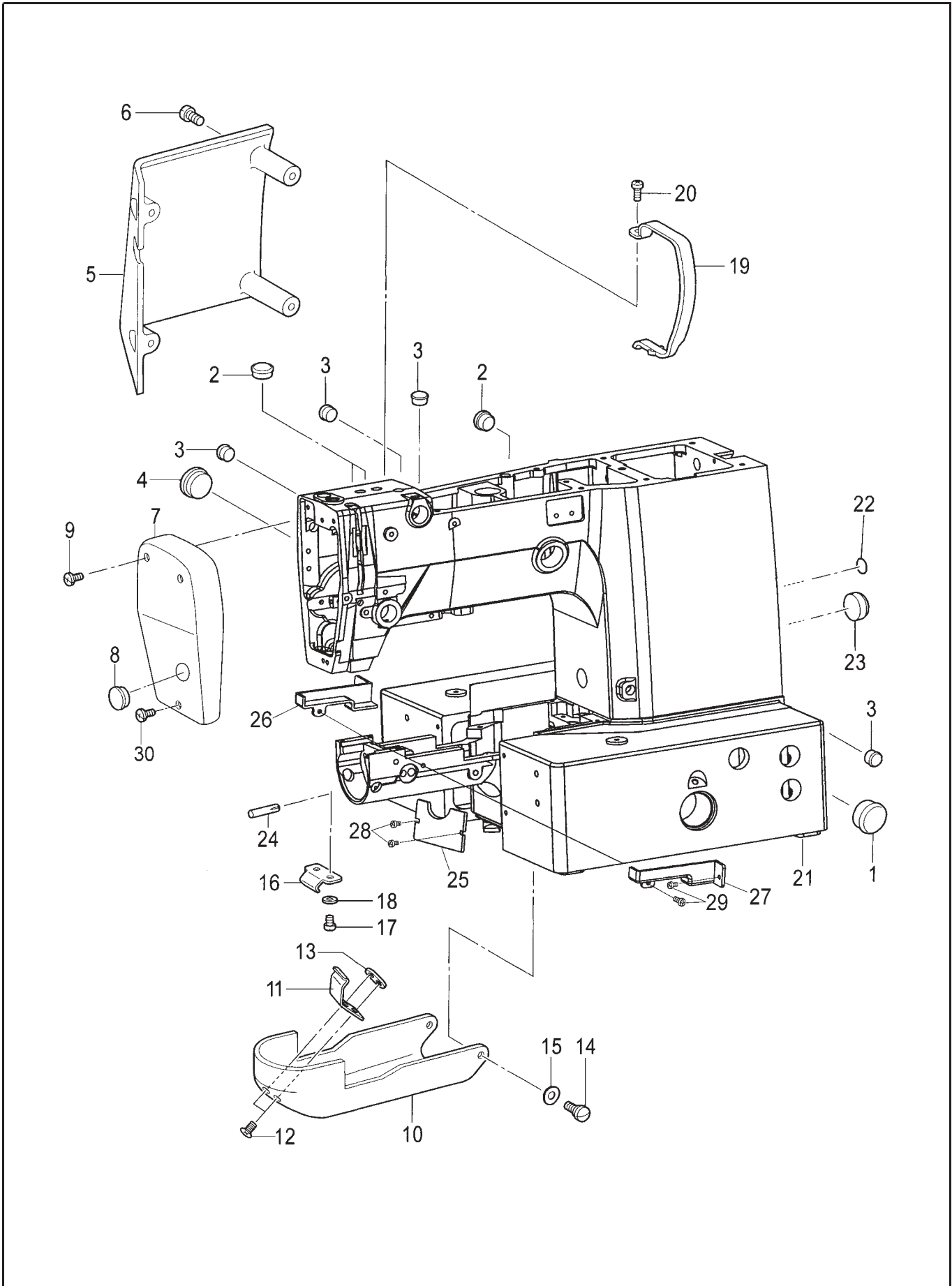

1. Machine body

No.	Ref.No.	Description	Qt.	Note
1	B960718001	Oil cap	1	
2	B993176009	Rubber cap 13.5	3	
3	B906289009	Rubber cap 10.5	10	
4	B960718001	Oil cap	1	
5	213000004	Side cover	1	
6	B048049094	Screw M6X10	4	
7	213000003	Face plate	1	
8	B906661009	Rubber cap 15.5	1	
9	B048509094	Screw M5X10	2	
10	BXF6646009	Shuttle race cover	1	
11	BXF7847009	Shuttle race cover hook D	1	
12	B006700597	Screw M3X5	2	
13	BXF7846009	Plate nut	1	
14	BXF7845009	Shoulder screw 8-2	2	
15	B901871008	Washer	2	
16	BXF7844009	Shuttle race cover hook U	1	
17	B048700694	Screw M3X4	2	
18	B085070874	Washer M3	2	
19	BXF7800909	Thread take-up cover	1	
20	B048609004	Screw M4X10	1	
21	BX72761009	Label	1	
22	036E02002	Label, Grounding	1	
23	BX82066009	Rubber cap 20.8	1	
24	S150435018	Pin B4x20	1	
25	234000001	Front baffle	1	
26	234000002	Left cover	1	
27	234000003	Right cover	1	
28	B048509094	Screw M5x10	2	
29	B048600294	Screw M4x8	4	
30	B048500294	Screw M5x8	1	

2. Upper shaft and needle bar mechanism

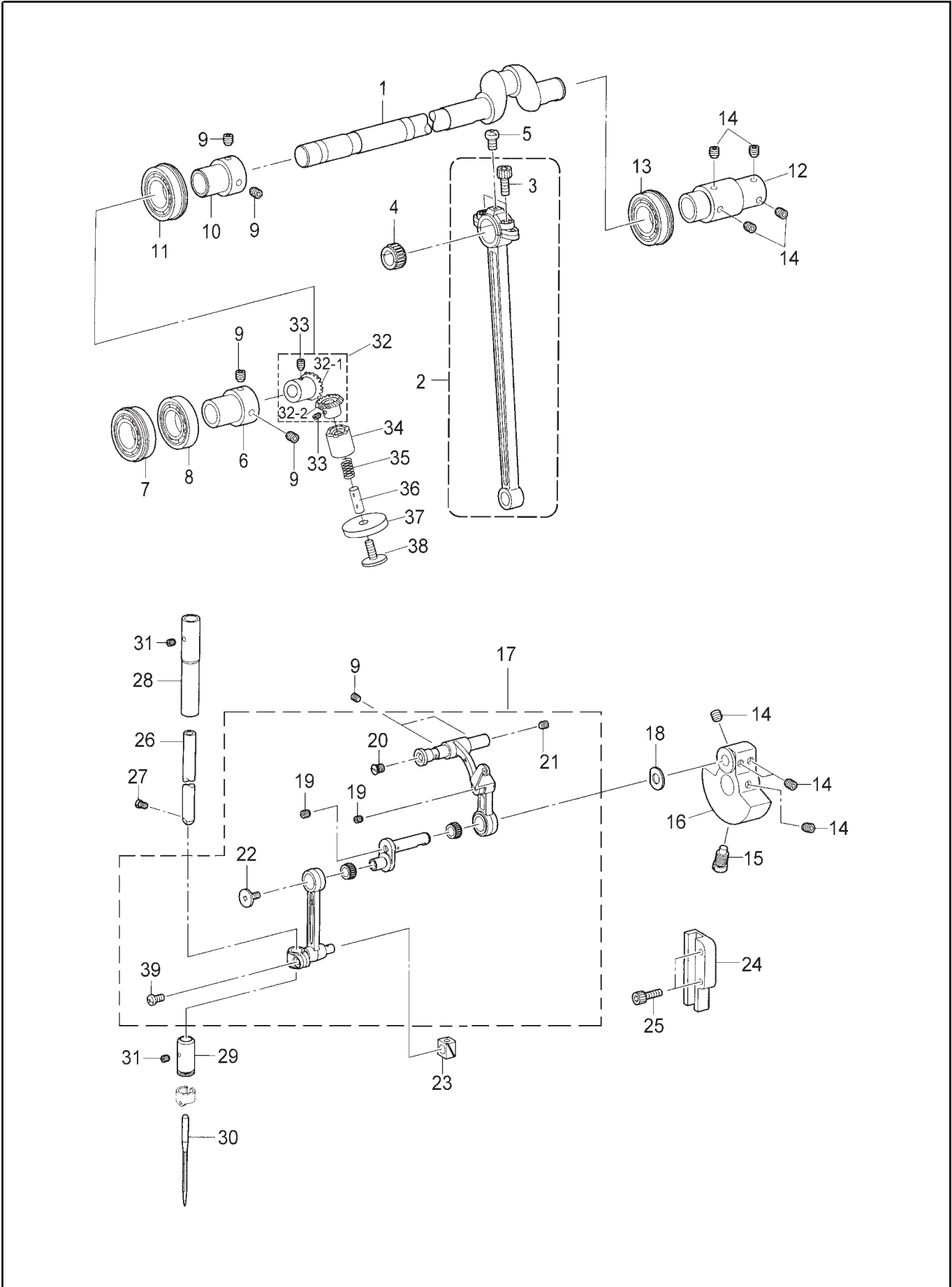

2. Upper shaft and needle bar mechanism

No.	Ref.No.	Description	Qt.	Note
1	BXF7809009	Upper shaft	1	
2	BXF7611009	Connecting assy	1	
3	B092509474	Bolt,Socket M5×16	2	
4	BXF7843009	Needle bearing H	2	Optiona
4	BXF7818009	Needle bearing H	2	Optiona
4	BXF7650009	Needle bearing H	2	Optiona
4	BXF7626009	Needle bearing H	2	Optiona
5	B048700694	Screw M3X4	1	
6	BXF7804009	Ball bearing bush	1	
7	BXF6931009	Ball bearing, 6904ZZNR	1	
8	BXF6920009	Ball bearing R-6904ZZ	1	
9	B098040474	Set screw M6X6	6	
10	BXF7804009	Ball bearing bush	1	
11	S150866037	Ball bearing 6004ZZNR	1	
12	213101001	coupling A	1	
13	S150866006	Ball bearing 6204ZZNR	1	
14	BX87459009	Set screw M6X6	8	
15	BX85875009	Screw M8	1	
16	BXF7613009	Thread take-up crank,C	1	
17	213102000	Thread take-up lever,assy	1	
18	B990743009	Washer 8	1	
19	B098700774	Set screw M3x3	2	
20	BXF8152009	Screw M5x6	1	
21	B098500574	Set screw M5x5	1	
22	B965465009	Screw SM3.57-40×6L	1	
23	BXF7622009	Slide block	1	
24	BXF7582009	Slide block guide	1	
25	B092609474	Bolt,Socket M4X16	2	
26	BXF7888009	Needle bar	1	
27	B966652009	Screw SM3.57-40X4.5	1	
28	BXF7887009	Needle bar bush,U	1	
29	BXF7886009	Needle bar bush,D	1	
30	※	Needle	1	
31	B098500574	Bolt,Socket M5X5	2	
32	B929018009	Bevel gear assy	1	
32-1	B994336009	Upper shaft Bevel gear	1	
32-2	B994111009	Vertical shaft Bevel gear U	1	
33	B096330488	Screw SM6.35	4	
34	213100006	Hand wheel bush	1	
35	B958232009	Spring	1	
36	213000011	Hand wheel shaft	1	
37	T2D280203	Hand wheel	1	
38	213000012	Screw M4X8	1	

3. Follow-up mechanism

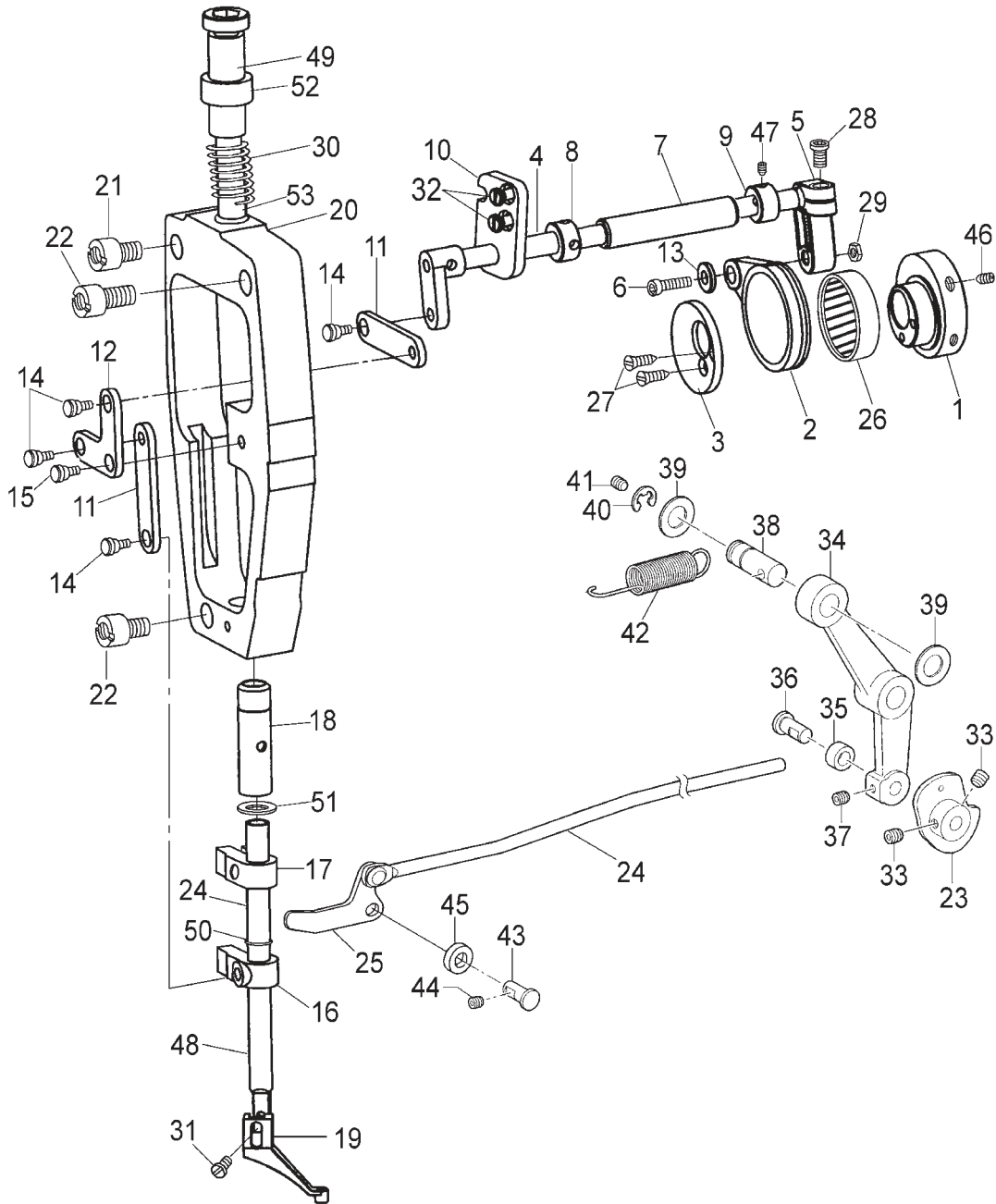

3. Follow-up mechanism

No.	Ref.No.	Description	Qt.	Note
1	234020001	Eccentricity crank	1	
2	234020002	Swing crank lever	1	
3	234020003	Eccentricity crank cap	1	
4	234020004	Swing lever	1	
5	234020005	Crank lever	1	
6	234020018	Shaft positioning screw 7-8	1	
7	234020006	Swing lever bush	1	
8	234020007	Ring tightener F	1	
9	234020008	Ring tightener B	1	
10	234020009	Bracket	1	
11	234020010	Connecting lever 1	2	
12	234020011	Connecting lever 2	1	
13	234020021	Washer	1	
14	234020020	Shaft positioning screw 2	4	
15	234020019	Spiral positioning screw 3	1	
16	234020012	Fixed sliding block for pressing foot	1	
17	234020013	Moved sliding block for pressing foot	1	
18	234020015	Middle pressing foot bush	1	
19	234020016	Middle pressing foot	1	
20	234020022	Faceplate lining	1	
21	234020023	Faceplate screw(long)	1	
22	234020024	Faceplate	2	
23	234020017	pressing foot lifter cam	1	
24	234021000	pressing foot lifter assy	1	
25	234021001	pressing foot lifter crank	1	
26	S150866069	All bearing 6805vv	1	
27	BX09414009	Screw SM3.57-40x6	2	
28	B092509878	Screw M5x12	1	
29	S120501005	Nut M5x0.5	1	
30	B969382009	pressing bar spring	1	
31	022700015	Screw SM 3.57-40x1	1	
32	BXF7572009	Screw M4x8	2	
33	B098040474	Set screw M6X6	2	
34	BXF7662009	Thread wiping driven lever	1	
35	BXF7661009	Thread wiping roller	1	
36	BXF7669009	W-Clamp lifter roller shaft	1	
37	B098500574	Set screw M5X5	1	
38	BXF7659009	Thread wiper rod shaft	1	
39	BX80754009	Washer 10	2	
40	B062020768	Retaining ring E8	1	
41	B098500574	Set screw M5X5	1	
42	BXF7664009	Spring	1	
43	BXF7669009	W-Clamp lifter roller shaft	1	
44	B098500574	Set screw M5X5	1	
45	234020025	Collar	1	
46	BX87459009	Screw M6X6	2	
47	B098600674	Set screw M4X4	4	
48	BXF9939009	Pressing foot bar	1	
49	022750001	Pressure adjustment screw	1	
50	B956514000	Vibration absorption washer	1	
51	B960603009	Washer	1	
52	022750002	Pressure adjustment nut	1	
53	234020026	Spring guiding bar	1	

4. Feed mechanism

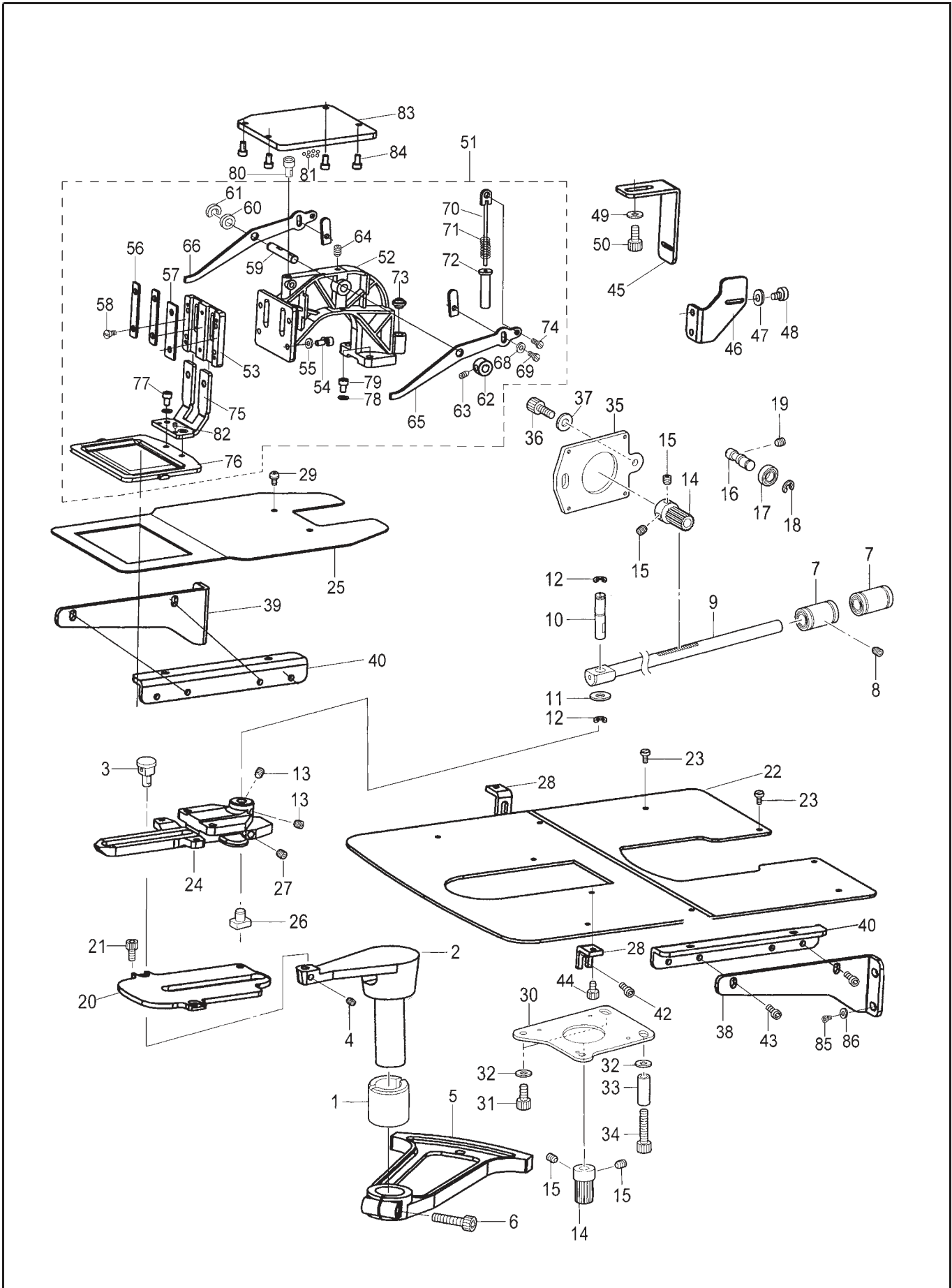

4. Feed mechanism

No.	Ref.No.	Description	Qt.	Note
1	BXF7747009	X-Feed lever bush	1	
2	234030002	X-Feed lever	1	
3	BXF7577009	T-Length regurator block assy	1	
4	B098500574	Set screw M5x5	1	
5	234030001	X-Feed gear	1	
6	B092047074	Bolt, Socket M6X30	1	
7	BXH5320009	Bearing10, Liner	2	
8	B098040474	Set screw M6X6	2	
9	234030005	Y-Feed rack shaft	1	
10	BXF7742009	Y-Connecting pin	1	
11	B957997009	Thrust washer	1	
12	B062040768	Retaining ring E6	2	
13	B098040474	Set screw M6X6	2	
14	BXF6913009	Feed gear	2	
15	B098040474	Set screw M6X6	4	
16	BXF7730009	Eccentric shaft	1	
17	B030402200	Ball bearing , Ardial 608ZZ	1	
18	B062020968	Retaining ring ,External C8	1	
19	B098040474	Set screw M6X6	1	
20	234030003	Feed bar support plate	1	
21	B092609074	Bolt, Socket M4X10	3	
22	234030009	Feed bar cover	1	
23	BXF7572009	Screw M4X8	4	
24	234030004	Feed bar sub	1	
25	234030008	Feed plate	1	
26	BXF7576009	T-Width regurator brock assy	1	
27	B098040474	Set screw M6X6	1	
28	234030010	Small table bracket	2	
29	B957053909	Screw SM4.37	2	
30	BXF7729009	X-Motor setting plate	1	
31	B092049874	Bolt, Socket M6X12	2	
32	B085040874	Washer M6	3	
33	BXF7302009	Collar	1	
34	B092047574	Bolt, Socket M6X35	1	
35	BXF7728009	Y-Motor setting plate	1	
36	B092049874	Bolt, socet M6X12	2	
37	B085040874	Washer M6	2	
38	23403012	Right holder	1	
39	234030011	Left holder	1	
40	234030013	Big table bracket	2	
42	B092509878	Bolt M5X12	2	
43	S150220007	Bolt M5X10	4	
44	S150220078	Bolt M4X6	6	
45	234030015	Detector fixing plate X	1	
46	234030014	Detector fixing plate Y	1	
47	B964756009	Washer 5	2	

4. Feed mechanism

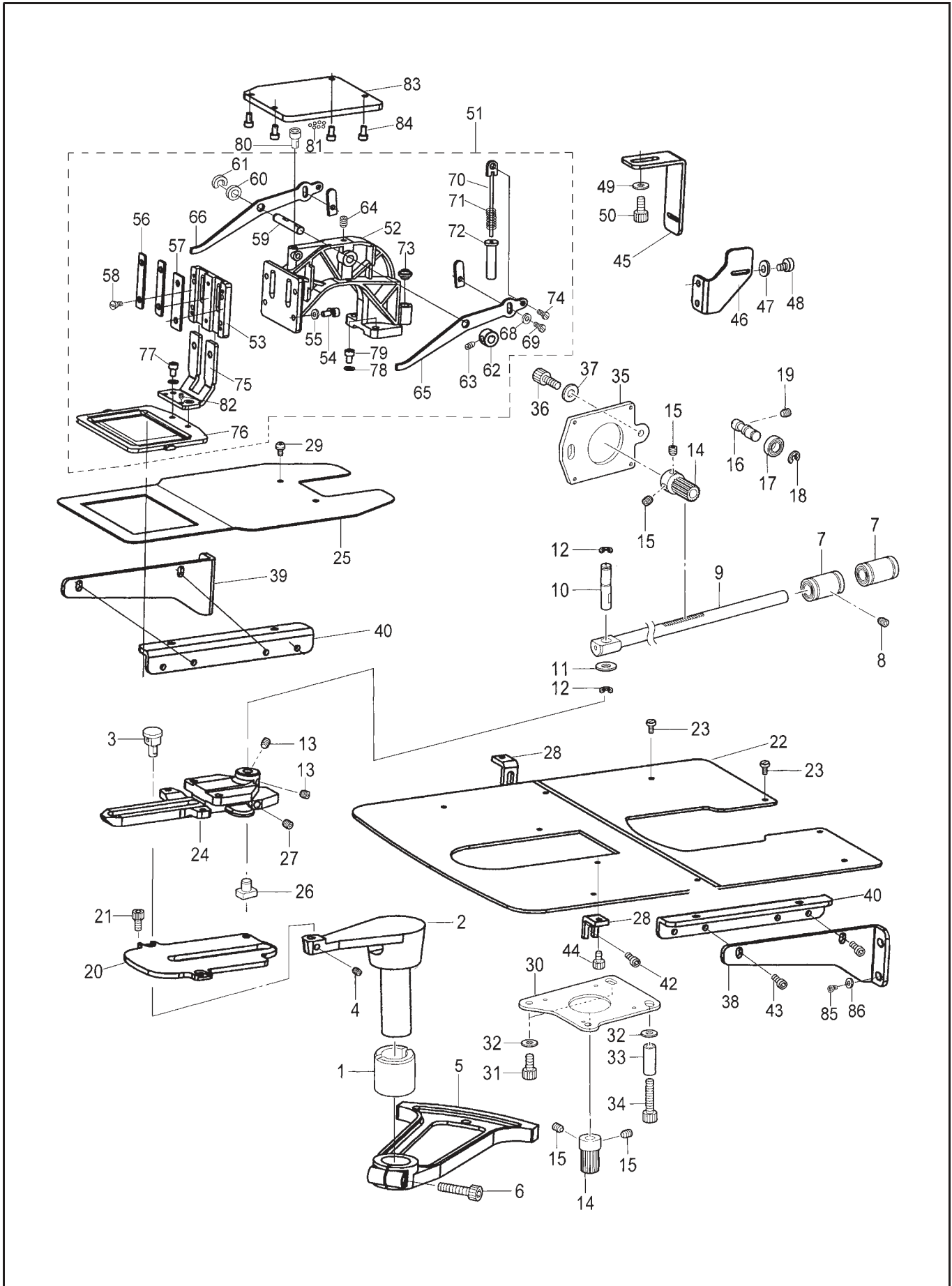

4. Feed mechanism

No.	Ref.No.	Description	Qt.	Note
48	S150220007	Bolt M5x10	2	
49	B085040874	Washer 6	2	
50	B092049874	Bolt M6x12	2	
51	234031000	Pressing foot arm assy	1	
52	234031001	Pressing foot arm	1	
53	234031002	Pressing foot sliding track	1	
54	B092509878	Screw M5x12	4	
55	B085050874	Washer 5	4	
56	234031003	Pressing plate C	2	
57	234031004	Pressing plate D	1	
58	BXF7684009	Screw M3.5	6	
59	234031005	Lever shaft	1	
60	B990743009	Washer 8	1	
61	B062040764	Retaining ring	1	
62	BXF7879009	Tightening ring	1	
63	B098040574	Set screw M6x5	2	
64	B098500574	Set screw M5x5	1	
65	234031006	Lever R	1	
66	234031007	Lever L	1	
67	234031008	Foot lifter adjustment plate	2	
68	B964756008	Washer 5	2	
69	B092500274	Bolt M5x8	2	
70	BXF7683009	Spring guiding lever	2	
71	B957542009	Spring A	2	
72	B957530009	Spring guiding bar	2	
73	B958322000	Spring positioning ring	2	
74	BXF9931008	Screw M5	2	
75	234031009	Pressing foot handle	1	
76	234030006	Application pressing frame	1	
77	J038440551	Bolt M5x8	2	
78	B085040874	Washer 6	2	
79	B092049474	Bolt M6x16	2	
80	BXF7682009	Short shaft	1	
81	B039079260	Steel ball 1/8"	7	
82	B098600674	Set screw M4x4	2	
83	234030007	Support plate	1	
84	B092600274	Bolt M4x8	4	
85	B092049874	Bolt M6x12	4	
86	B085040874	Washer 6	4	

5. Work clamp lifter mechanism

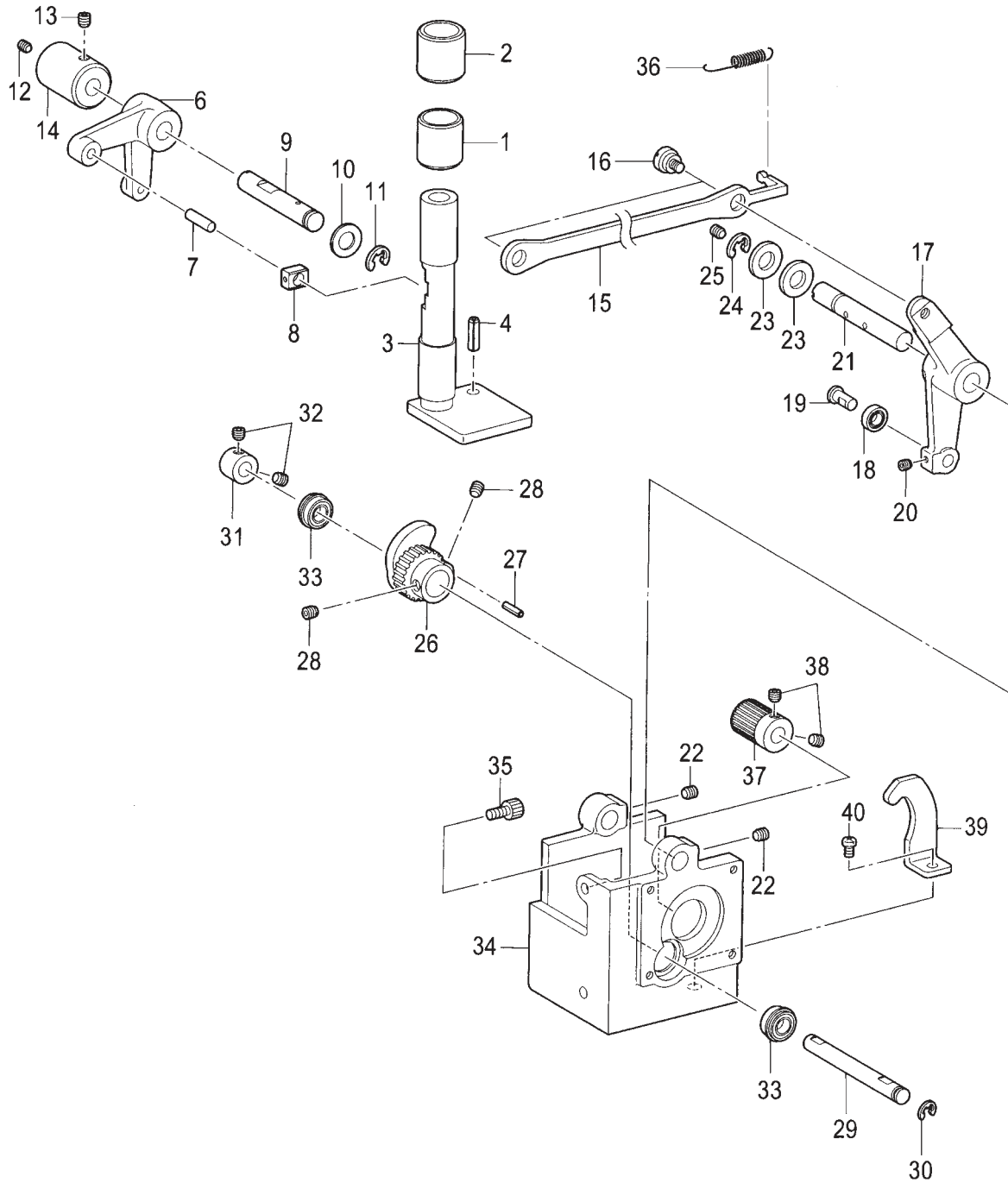

5. Work clamp lifter mechanism

No.	Ref.No.	Description	Qt.	Note
1	BXF7681009	Footlifter bush D	1	
2	BXF7670009	Footlifter bush U	1	
3	234040001	Work clamp lifter plate	1	
4	B063408068	Pin, Spring roll 6x25	1	
6	BXF7676009	Lifter lever	1	
7	B958366009	Pin	1	
8	B908470009	Needle bar guide slide block	1	
9	BXF7675009	Lever shaft	1	
10	BX80754009	Washer 10	1	
11	B062020768	Retaining ring E8	1	
12	B098500574	Set screw M5x5	1	
13	B098040474	Set screw M6X6	1	
14	BXF7674009	W-Clamp lifter lever bush	1	
15	BXF7673009	Link	1	
16	BXF7672009	Link shoulder screw	2	
17	BXF7671009	Drive lever W-Clamp	1	
18	B030414200	Ball bearing R-696ZZ	1	
19	BXF7669009	W-Clamp lifter roller shaft	1	
20	B098500574	Set screw M5x5	1	
21	BXF7668009	Cam lever shaft	1	
22	B098040474	Set screw M6X6	2	
23	BX80754009	Washer 10	2	
24	B062020768	Retaining ring E8	1	
25	B098500574	Set screw M5x5	1	
26	BXF7667009	Cam gear	1	
27	B063709068	Pin, spring 3x10	1	
28	B098040474	Set screw M6X6	2	
29	BXF7666009	Cam shaft	1	
30	B062040768	Retaining ring E6	1	
31	BXF7879009	Set screw collar	1	
32	B098040574	Set screw M6X5	2	
33	B030422250	Ball bearing ,Radial 688ZZNR	2	
34	BXF7665009	Motor bracket	1	
35	B092049874	Bolt,socket M6X12	2	
36	213300001	Spring	1	
37	BXF7303009	Gear 16	1	
38	B098040574	Set screw M6X5	2	
39	BXF6038009	Stopper	1	
40	B048049094	Bolt,socket M6X10	1	

6. Lower shaft mechanism

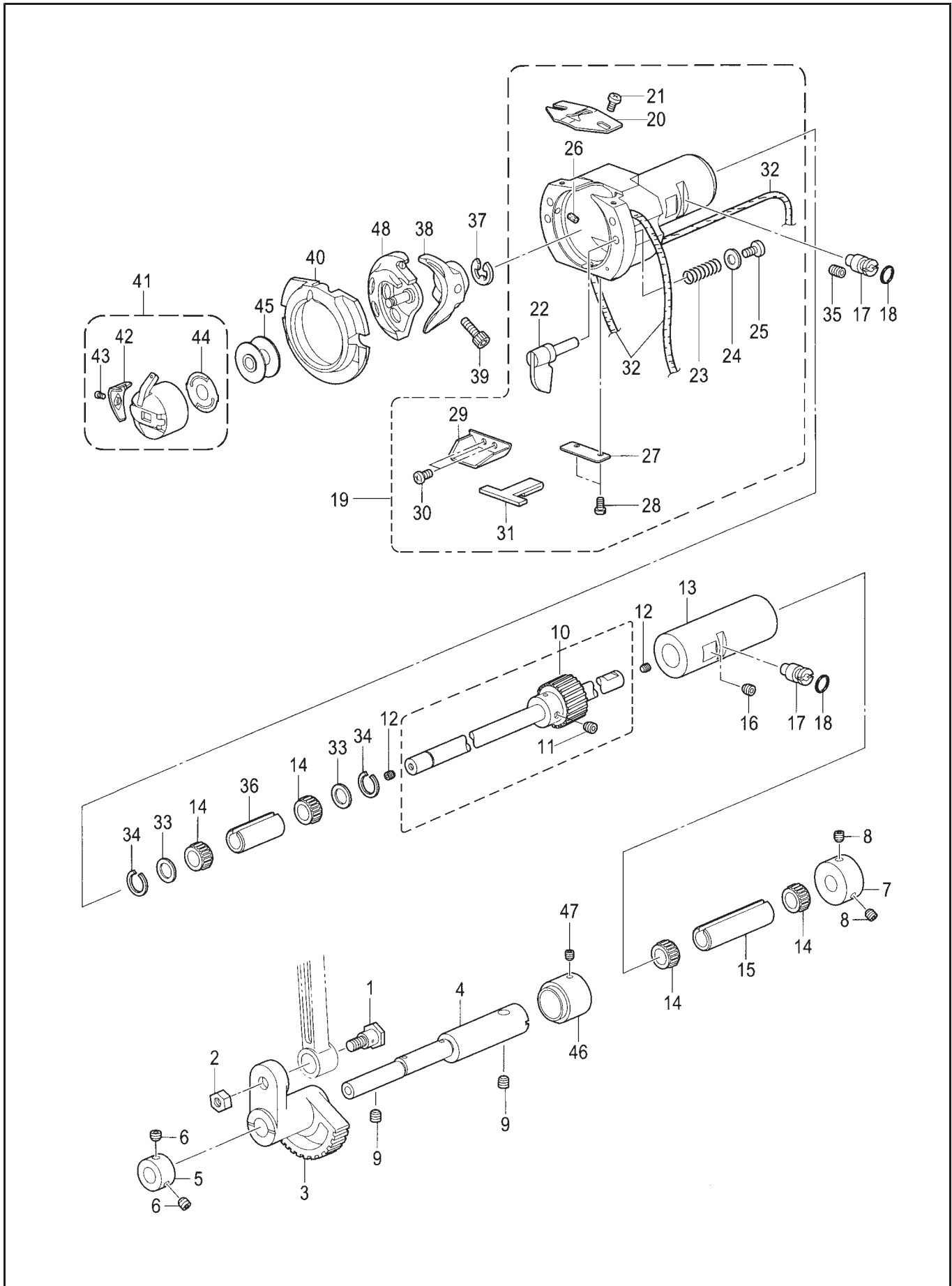

6. Lower shaft mechanism

No.	Ref.No.	Description	Qt.	Note
1	BXF7884009	Shoulder screw M6	1	
2	BXF7883009	Nut M6	1	
3	BXF7882009	Rock gear	1	
4	BXF6042909	Rock gear shaft	1	
5	BXF7879009	Set screw collar	1	
6	B098040574	Set screw M6X5	2	
7	BXF7877009	Set screw collar	1	
8	BX87459009	Set screw M6X6	2	
9	B098040474	Set screw M6X6	2	
10	BXF7876009	Lower shaft assy	1	
11	B098500574	Set screw M5X5	1	
12	B098600674	Set screw M4X4	2	
13	BXF7873009	Lower shaft bush	1	Optiona
14	BXF6923009	Needle bearing	4	Optiona
	BXF6922009	Needle bearing	4	Optiona
	BXF6921009	Needle bearing	4	Optiona
	BXF6910009	Needle bearing	4	
15	BXF7837009	Lower shaft collar	1	
16	B098040474	Set screw M6X6	1	
17	BXF7872909	Pin	2	
18	B029007430	O ring PW3	2	
19	234051000	Shuttle race base assy	1	
20	BX08681809	Shuttle race thread	1	
21	S150217009	Screw M3X4	2	
22	BXF7869009	S-Race base setting claw	2	
23	B958426909	Compression spring	2	
24	B084070974	Washer S3	2	
25	B048700494	Screw M3X6	2	
26	B957050000	S-Race base felt	2	
27	BXF7868909	Felt holder	1	
28	S150217009	Screw M3X4	2	
29	BXF7836909	Felt holder	1	
30	S150217009	Screw M3X4	2	
31	BXF7835009	Felt T	1	
32	BX51224009	Oil Thread L=380	3	
33	BXF7834009	Washer	2	
34	213420002	Wire ring 12	2	
35	B098040474	Set screw M6X6	1	
36	BXF7832009	Collar	1	
37	B062030768	Retaining ring E7	1	
38	BXF7826009	Driver	1	
39	B092509878	Bolt,socket M5X12	1	
40	※	Shuttle race base	1	
41	B951490609	Bobbin case assy	1	
42	B956771909	Tension spring	1	
43	B956769009	Screw	1	
44	B951498009	Anti-spin spring	1	
45	B951497059	Bobbin	1	
46	BXF7827009	Set screw collar	1	
47	B098500574	Set screw M5x5	1	
48	※	Shuttle hook	1	

7. Lubrication

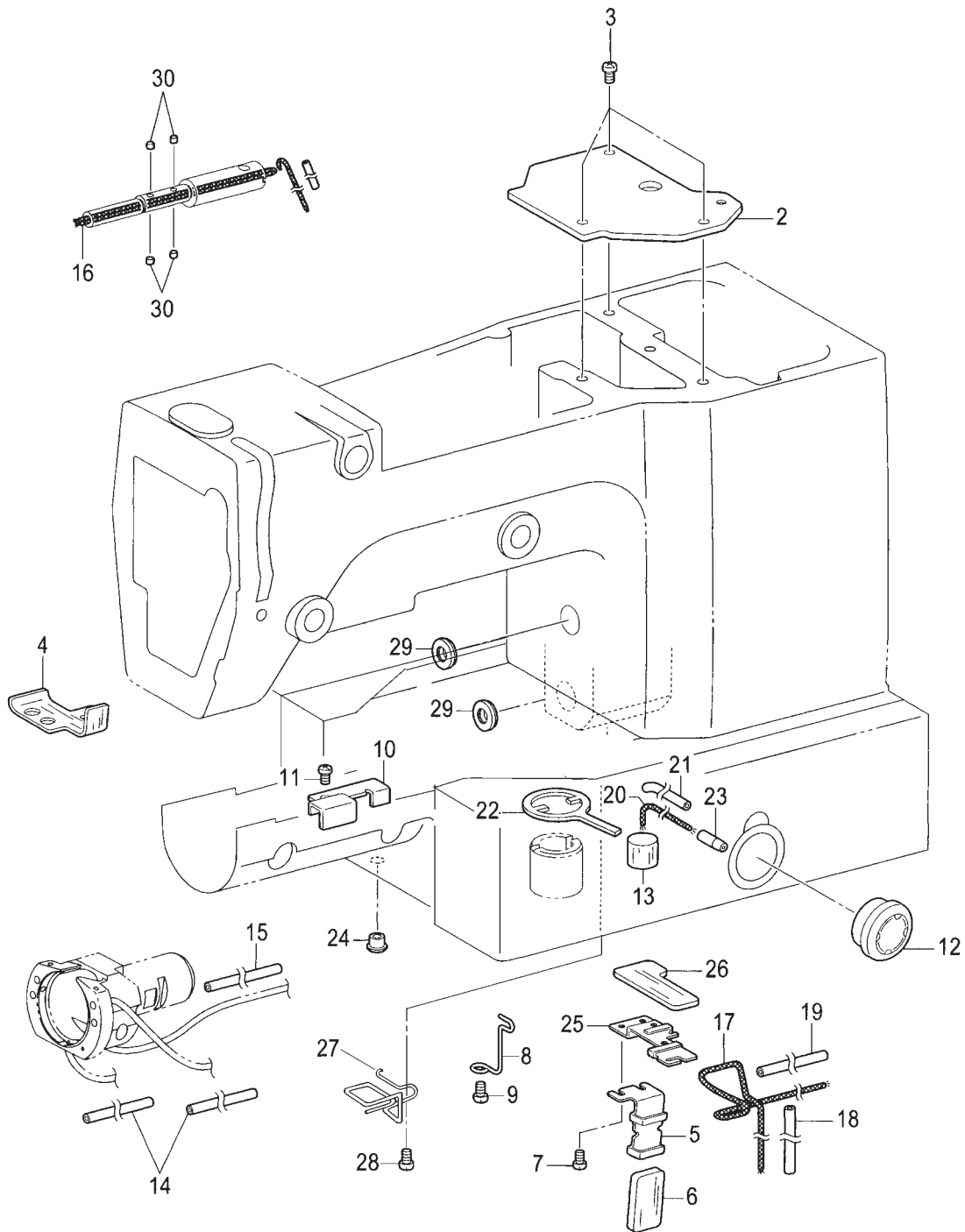

7. Lubrication

No.	Ref.No.	Description	Qt.	Note
1	BXF7866009	Set screw	1	
2	BXF7865009	Crank cover	1	
3	B048040294	Screw M6X8	3	
4	BXF7831009	Felt	1	
5	BXF7507809	Lower shaft wick support	1	
6	BXF7506809	Lower shaft gear felt	1	
7	B048600494	Screw M4X6	2	
8	BXF7828009	Cord holder	1	
9	B048040294	Screw M6X8	1	
10	BXF7861009	Oil tube support	1	
11	B048600494	Screw M4X6	1	
12	213501000	Oil gauge window	1	
13	BXF7731009	Felt	1	
14	BX50581000	Oil tube L=300	2	
15	BX82695000	Oil tube L=225	1	
16	BX65261000	Wick 4x4 L=320	1	
17	B957188009	Wick L=510	1	
18	BXF9708009	Oil tube L=120	1	
19	BX54233000	Oil tube L=150	1	
20	BX76098000	Wick 4X4 L=220	1	
21	B967439000	Oil tube L=150	1	
22	BXF7823009	Felt	1	
23	BX03777009	Oil feeding pipe, S	1	
24	B964020000	Cord bush	1	
25	BXF7864009	Gear wick support	1	
26	BXF7820009	Gear felt	1	
27	BXF6648009	Cord holder	1	
28	B048040294	Screw M6X8	1	
29	BXF6888009	Oil cork	1	
30	B957050000	S-race base felt	4	

8. Threading mechanism

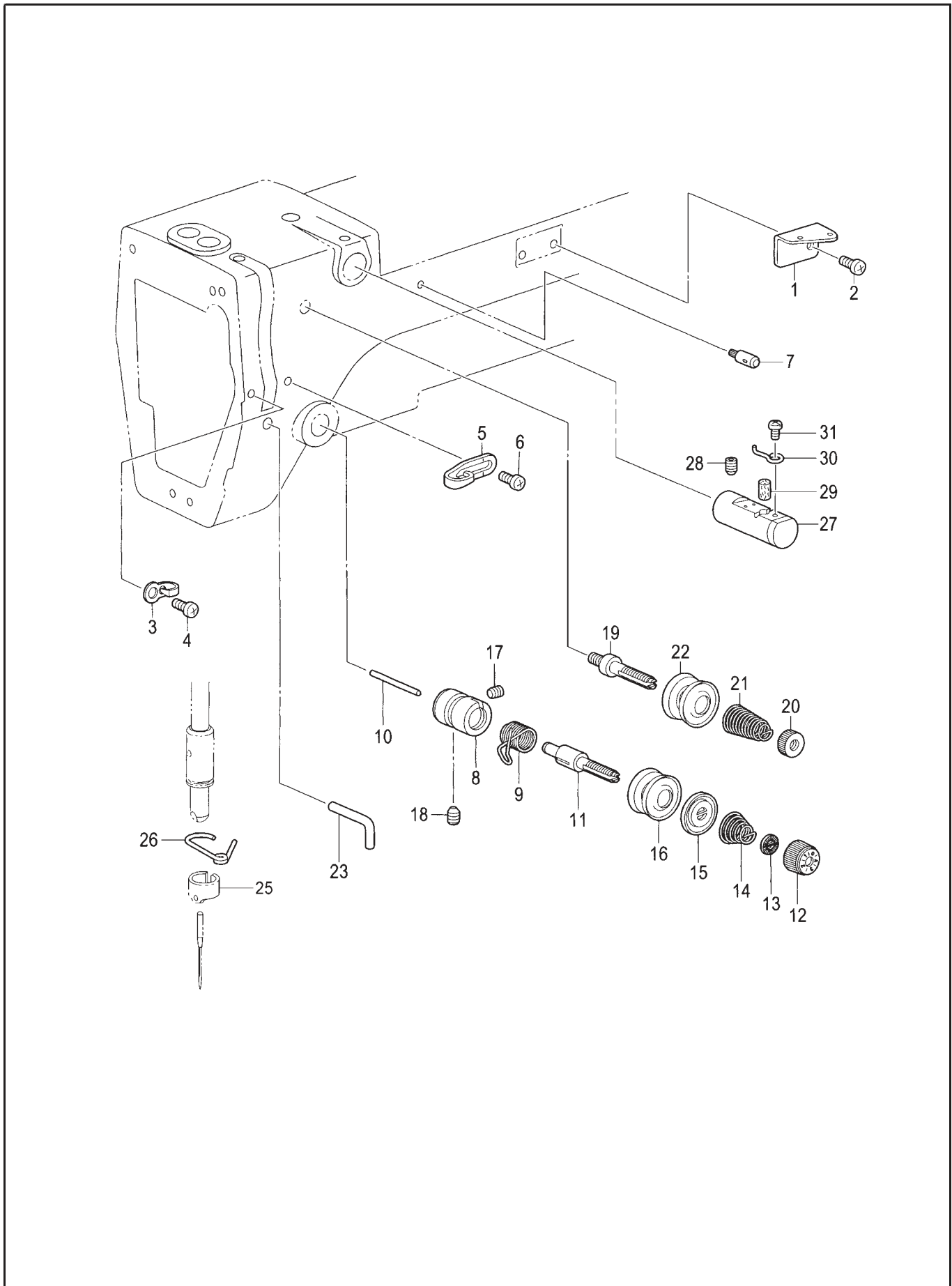

8. Threading mechanism

No.	Ref.No.	Description	Qt.	Note
1	BXF7850009	Arm thread guide , A	1	
2	B048500494	Screw M5X6	1	
3	BXF6777009	Arm thread guide , B	1	
4	B048500494	Screw M5X6	1	
5	BXF7858009	Arm thread guide , C	1	
6	B048500494	Screw M5X6	1	
7	B957061009	Upper thread guide stud	1	
8	BXF7856009	Tension bracket	1	
9	※	Thread take-up spring	1	
10	BX98411000	Tension release pin	1	
11	BXF7855009	Tension stud	1	
12	BX79078009	Tension nut	1	
13	BX98669009	Washer	1	
14	※	Tension spring	1	
15	B951205009	Tension disc presser	1	
16	B965664009	Disc ,Tension	2	
17	B900608006	Set screw SM3.57	1	
18	BXF9881909	Set screw M6X6	1	
19	BXF7854009	Tension stud	1	
20	B900974009	Tension nut	1	
21	BXF6964009	Sub tension spring	1	
22	B965664009	Disc ,tension	2	
23	B951886009	Thread guide ,Arm	1	
25	BXF7475009	Needle bar thread guide , B	1	
26	BXF7852009	N-bar bush thread guide	1	
27	B952229009	Needle cooler assy	1	
28	B098040474	Set screw M6X6	1	
29	B958227000	Felt 8X15.5	1	
30	B958226009	Needle cooler thread guide	1	
31	B048430698	Screw SM3.57-40X4	1	

9. Bobbin winder mechanism

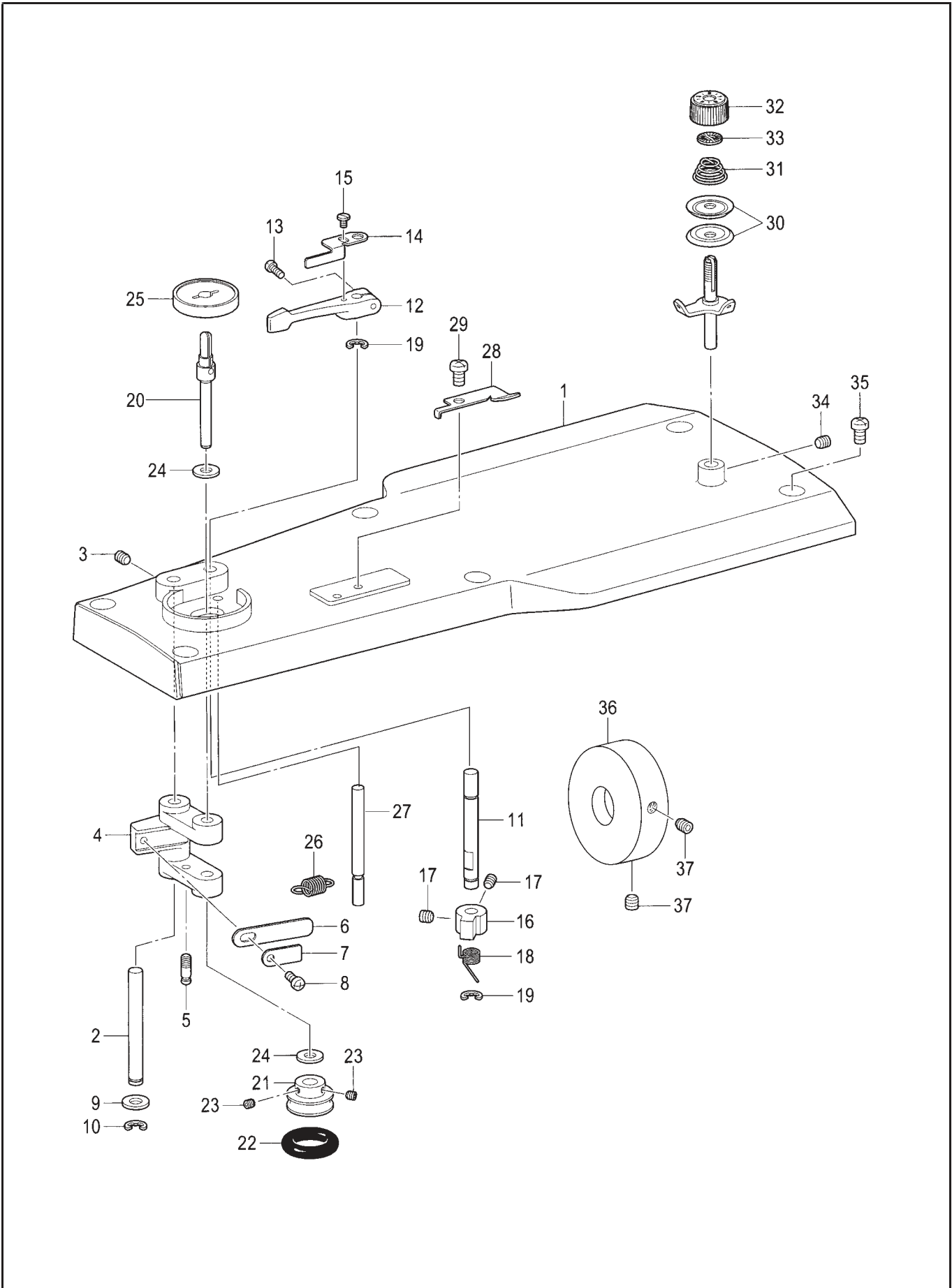

9. Bobbin winder mechanism

No.	Ref.No.	Description	Qt.	Note
1	BXF7821009	Top cover	1	
2	BXF7810009	Shaft ,Bw-lever	1	
3	B098500574	Set screw M5X5	1	
4	BXF7819009	Bobbin winder lever	1	
5	BXF6939009	Spring hook	1	
6	B958174009	Plate spring	1	
7	B958173009	Washer	1	
8	B048750494	Screw M3.5X6	1	
9	B951624009	Washer	1	
10	B062050768	Retaining ring E5	1	
11	BXF7817009	Stud,B-winder claw	1	
12	BXF9126009	Bobbin presser arm	1	
13	B048609894	Screw M4X12	1	
14	BXF7816009	Bobbin presser	1	
15	BX87692008	Screw M4X4.5	1	
16	BXF7815009	Claw,B-winder	1	
17	B098600674	Set screw M4X4	2	
18	BX90672009	Spring	1	
19	B062050768	Retaining ring E5	2	
20	BXF7814009	Bobbin winder shaft	1	
21	BXF7813009	Wheel, B-winder	1	
22	B980662009	Bobbin winder rubber band	1	
23	B098600674	Set screw M4X4	2	
24	B085040974	Washer S6	2	
25	BXF9122009	Bobbin support	1	
26	BX90842009	Spring	1	
27	BXF7812009	Stop shaft	1	
28	BXF7811009	Knife	1	
29	B048500494	Screw M5X6	1	
30	B965664009	Disc,Tension	2	
31	B900609089	Tension spring	1	
32	BX79078009	Tension nut	1	
33	BX98669009	Washer	1	
34	B098500574	Set screw M5X5	1	
35	B048049094	Screw M6X10	6	
36	234080001	Driving wheel	1	
37	BX87459009	Set screw M6X6	2	

10. Thread trimmer mechanism

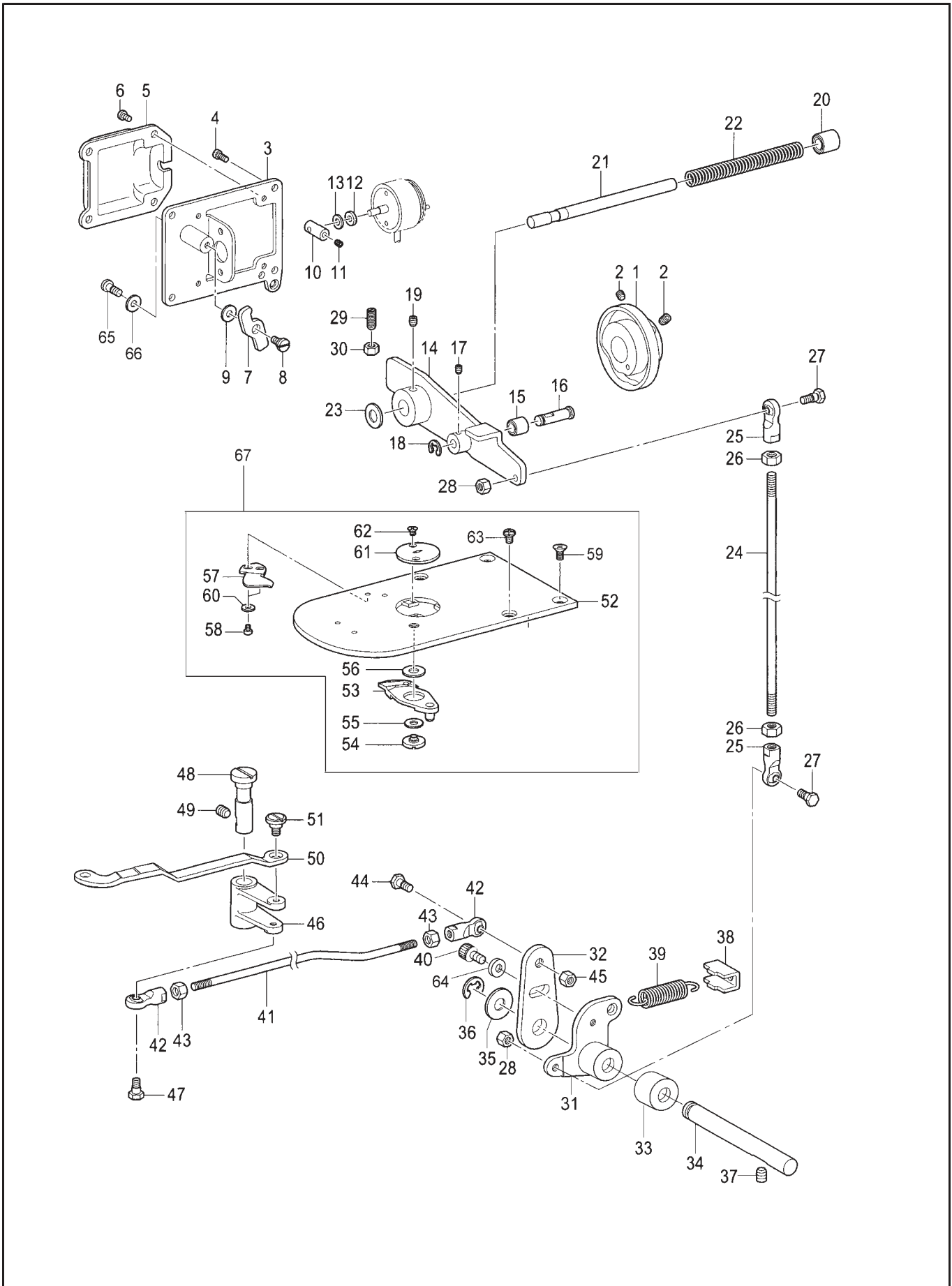

10. Thread trimmer mechanism

No.	Ref.No.	Description	Qt.	Note
1	213700005	Thread trimmer cam	1	
2	BX87459009	Set screw M6X6	2	
3	BXF7706009	Setting plate	1	
4	B048600294	Screw M4x8	4	
5	BXF7707009	Tr-solenoid cover	1	
6	B040600594	Screw M4x5	4	
7	BXF7705009	Pushing lever, Driving lever	1	
8	BXF7704009	Shoulder screw 7-3	1	
9	BX71410089	Washer	1	
10	BXF7703009	Solenoid lever	1	
11	B098600674	Set screw M4x4	1	
12	B956511000	Solenoid cushion	1	
13	BX08458009	Washer	1	
14	BXF7701009	Tr-driving lever	1	
15	BXF7790009	Collar , Tr-trimmer	1	
16	BXF7799009	Collar shaft	1	
17	B098600674	Set screw M4x4	1	
18	B062060768	Retaining ring E4	1	
19	BX87459009	Set screw M6x6	1	
20	B879039009	Bush 8x15	1	
21	BXF7798009	Guide shaft	1	
22	BXF7797009	Spring	1	
23	B956514000	Cushion	1	
24	BXF7795009	Thread trimmer rod V	2	
25	BX78645009	Ball joint assy	2	
26	B089040904	Nut M6	2	
27	BX78648009	Shoulder screw M6	2	
28	B089040704	Nut M6	1	
29	BX85635009	Set screw M6x19	1	
30	B089040904	Nut M6	1	
31	BXF6564009	Thread trimmer lever V	1	
32	BXF7793009	Thread trimmer lever H	1	
33	BXF7792009	Spacer ring	1	
34	BXF7791009	Shaft,Tr-trimmer lever	1	
35	B957514009	Washer 8	1	
36	B062030768	Retaining ring E7	1	
37	B098040474	Set screw M6x6	1	
38	BXF7780009	Spring	1	
39	BXF7789009	Spring ,Extension	1	

10. Thread trimmer mechanism

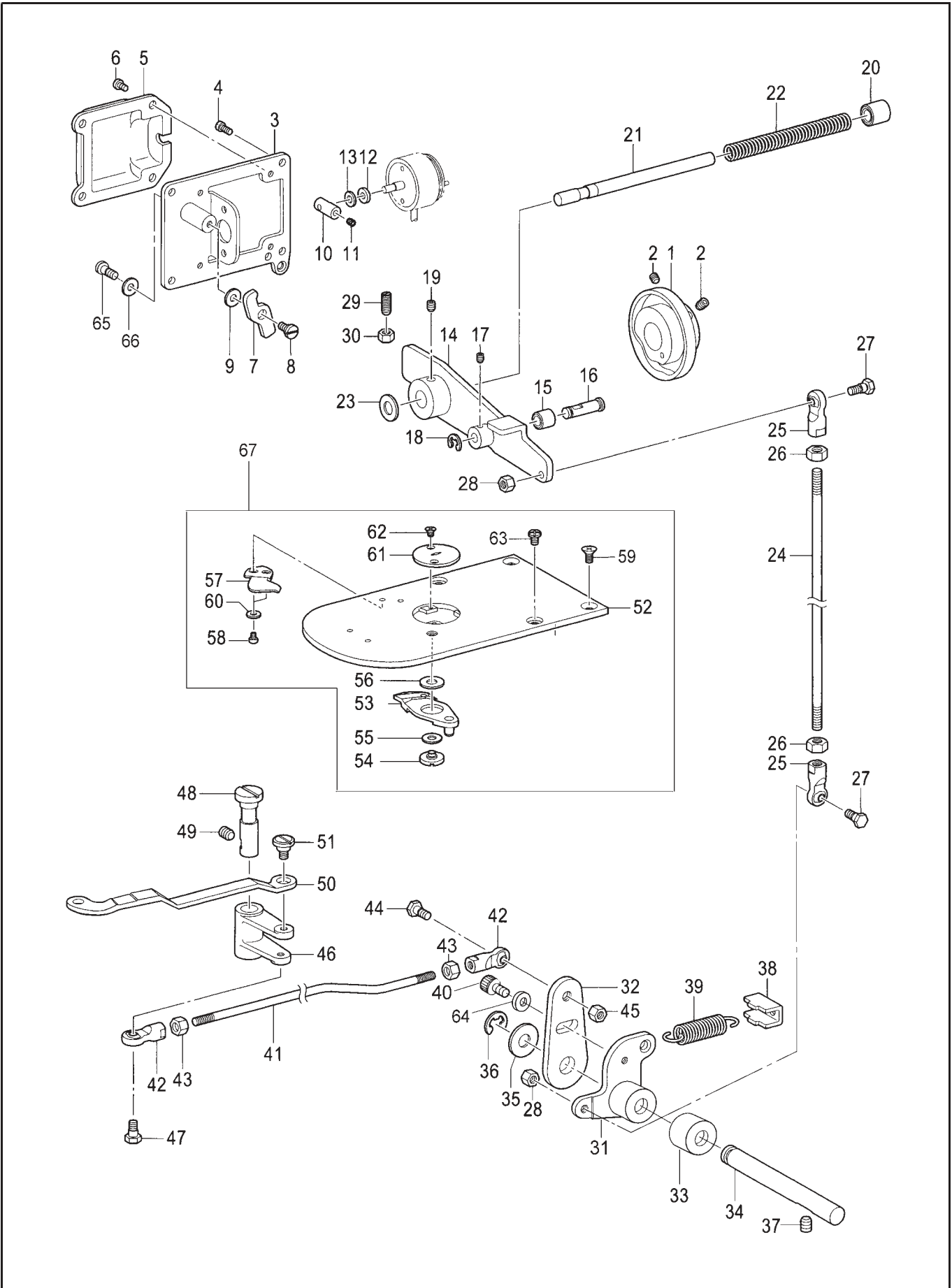

10. Thread trimmer mechanism

No.	Ref.No.	Description	Qt.	Note
40	S150220007	Bolt ,Socket M5x10	1	
41	BXF7787009	Thread trimmer rod H	1	
42	BX78645009	Ball joint assy	2	
43	B089040904	Nut M6	2	
44	BX78648009	Shoulder screw M6	1	
45	B089040704	Nut M6	1	
46	BXF7786009	Moving knife lever	1	
47	BXF7785009	Shoulder screw 6.35-6	1	
48	BXF7784009	Shaft,M-knife lever	1	
49	B098040474	Set screw	1	
50	234090001	M-knife connecting plate	1	
51	BXF7754009	Shoulder screw 6-2.2	1	
52	234090002	Needle plate SC	1	
53	BXF7454009	Moving knife assy	1	
54	BXF7777009	Shoulder screw	1	
55	BX003305009	Washer	1	
56	BXF4713009	Washer 0.2	1	
	BXF7776009	Washer 0.3	1	
	BXF4712009	Washer 0.4	1	
57	BXF7452009	Fixed knife	1	
58	B048700694	Screw M3x4	2	
59	BX85790909	Screw M4	2	
60	B085070874	Washer	2	
61	※	Needle holder plate	1	
62	B900740007	Screw SM2.38	2	
63	BXF7572009	Screw M4x8	2	
64	B964756009	Washer 5	1	
65	S150220001	Bolt M5x8	1	
66	S150632004	Washer ,big 5	1	
67	234092000	Needle plate assy	1	

11. Thread wiper mechanism

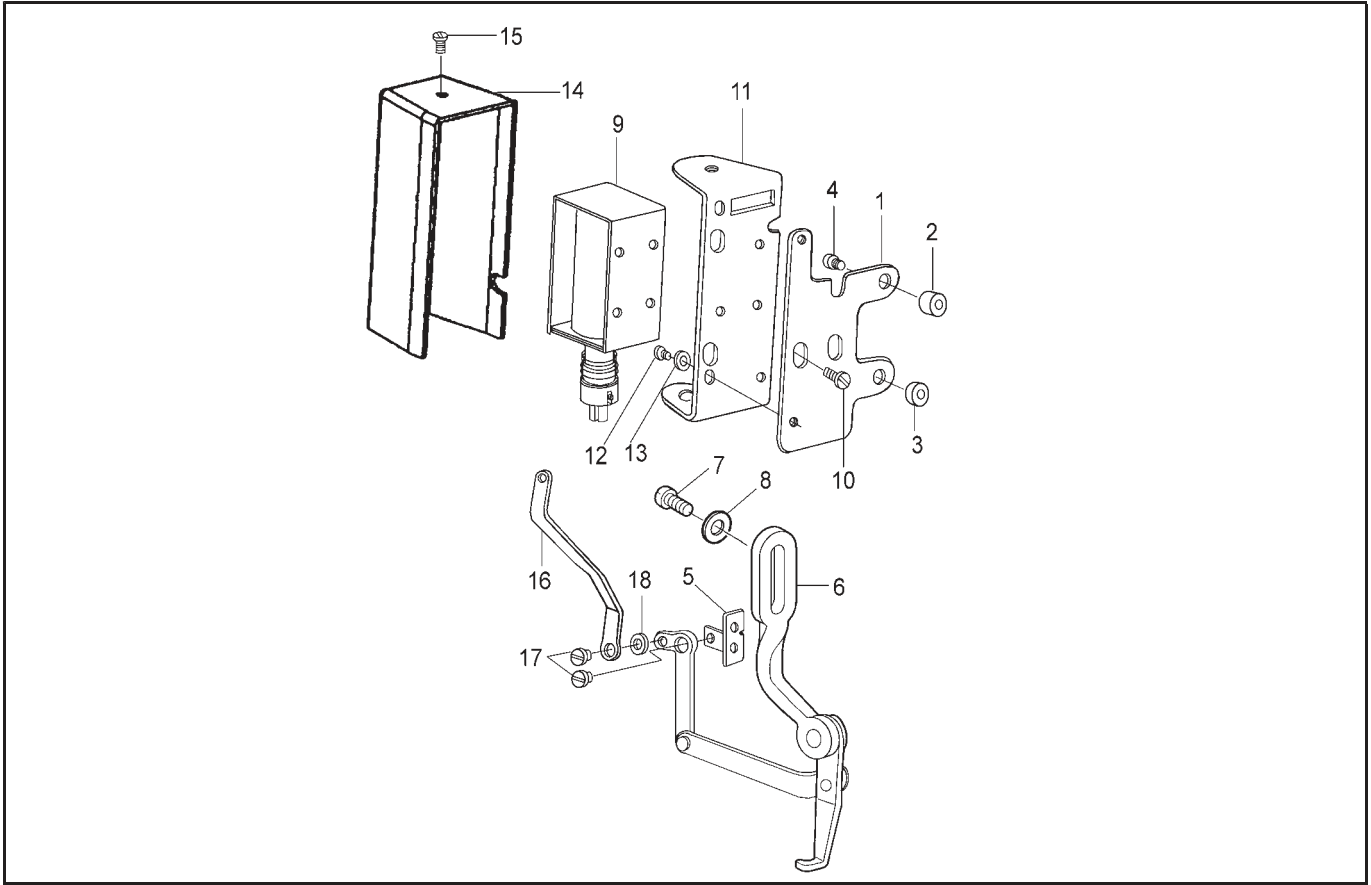

12. Tension release mechanism

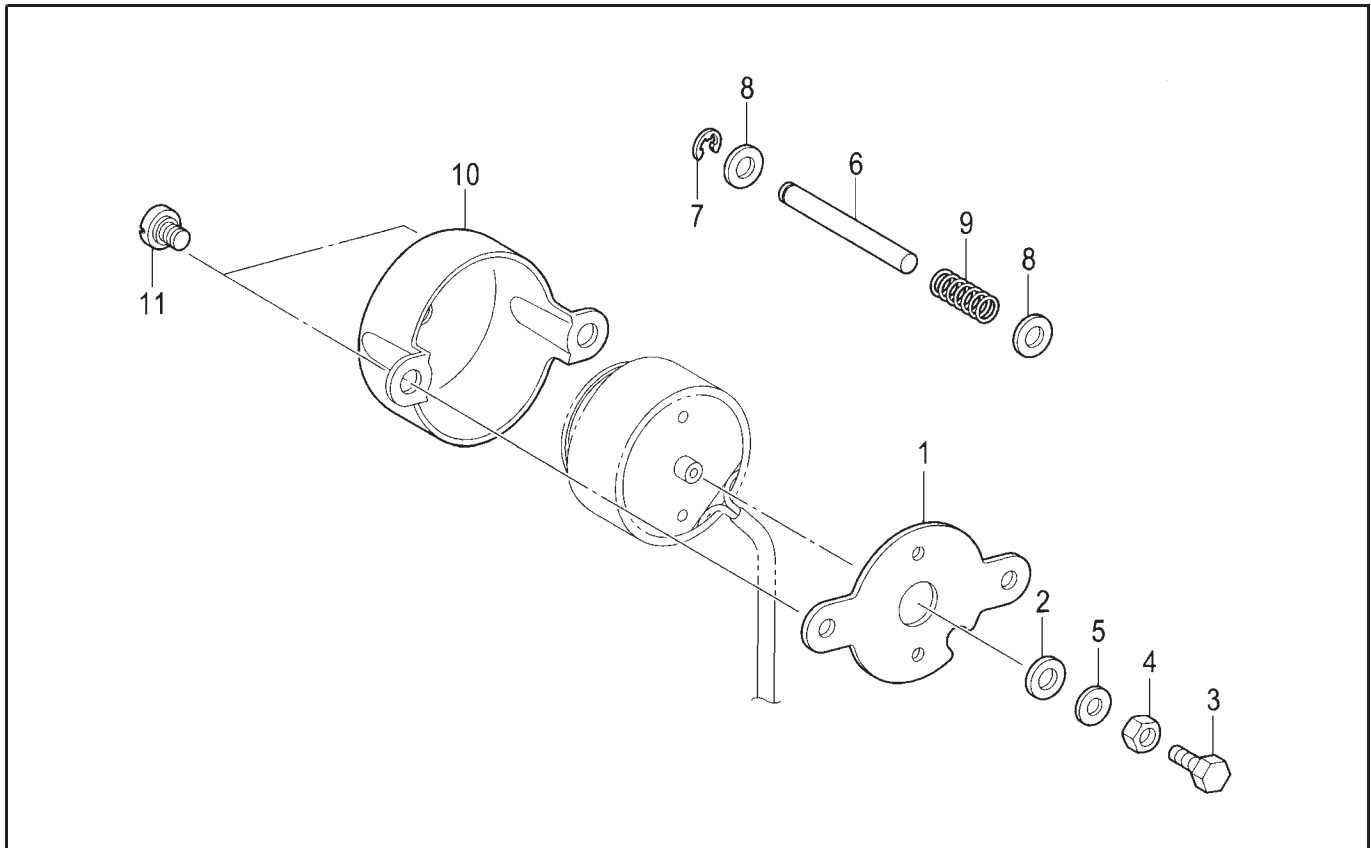

11. Thread wiper mechanism

No.	Ref.No.	Description	Qt.	Note
1	234100001	Solenoid board	1	
2	234100002	block U	1	
3	234100003	Block U	1	
4	J01540020	Hexagonal screw M5x16	2	
5	234100006	Fixing bracket	1	
6	234101000	Link lever assy for thread wiping	1	
7	B048609004	Screw M4x10	2	
8	B085060874	Washer	2	
9	234130005	Solenoid assy for thread wiping	1	
10	S8A3101005	Screw M3x6	3	
11	BX85661889	Fixing plate for solenoid	1	
12	B048600494	Screw M4x6	2	
13	B085060874	Washer 4	2	
14	BX77490989	Solenoid cover	1	
15	B040600594	Screw M4x5	1	
16	234100004	Driven lever for thread wiping	1	
17	234100005	Set screw 6-2	2	
18	B085060874	Washer 4	1	

12. Tension release mechanism

No.	Ref.No.	Description	Qt.	Note
1	BXF7765009	Fixing plate for solenoid	1	
2	B956511000	Solenoid cushion	1	
3	B093609095	Bolt , M4x10	1	
4	B089600704	Nut M4	1	
5	B085060874	Washer 4	1	
6	BXF7763009	Tension release bar	1	
7	B062060768	Retaining ring E4	1	
8	B085050874	Washer 5	2	
9	BXF7762009	Spring	1	
10	BXF7761009	Solenoid cover	1	
11	BXF7750009	Shoulder screw	2	

13. Control mechanism

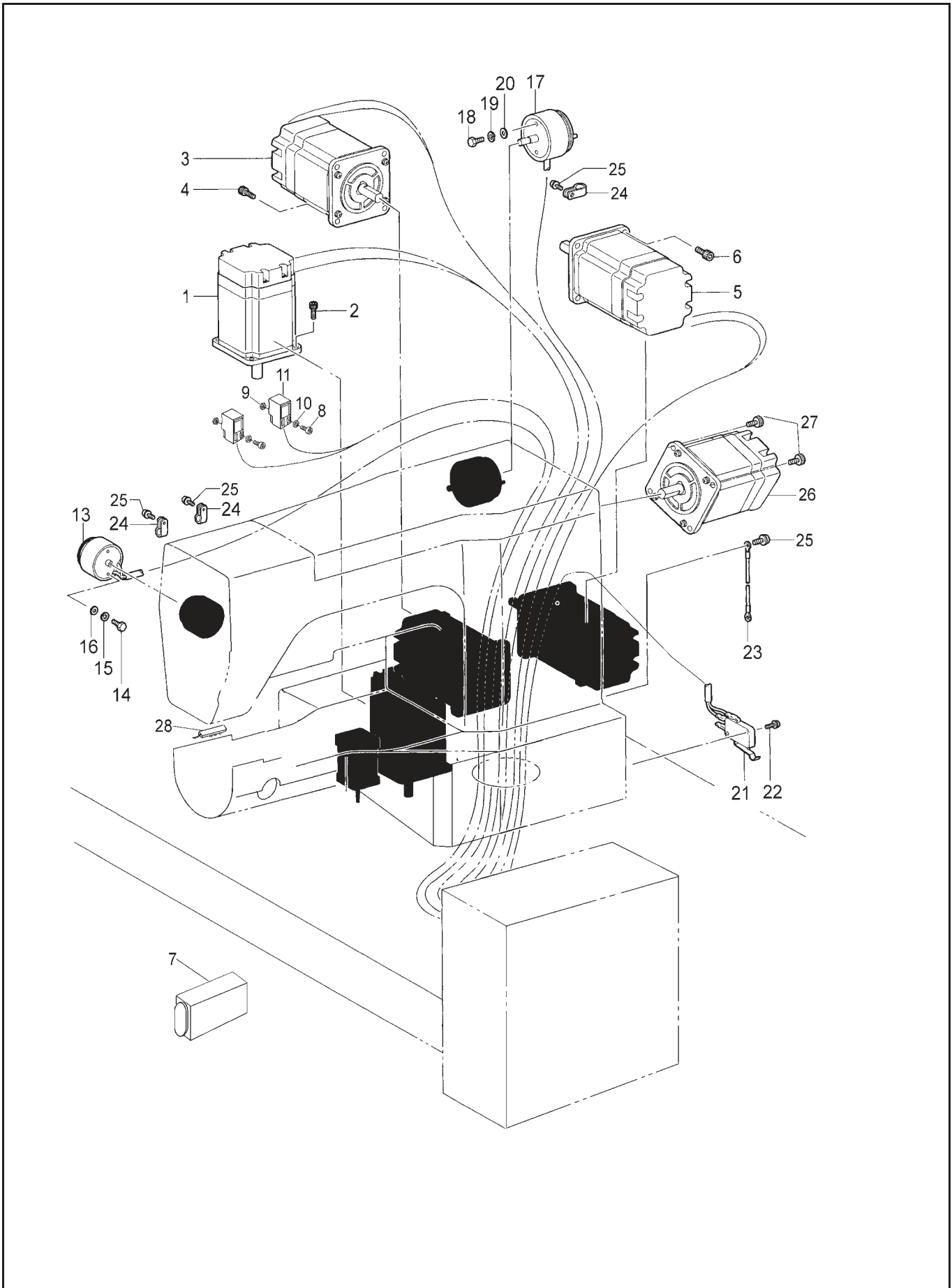

13. Control mechanism

No.	Ref.No.	Description	Qt.	Note
1	213907002	Feeding motor assy X	1	
2	B092609074	Bolt M4X10	4	
3	213907003	Feeding motor assy Y	1	
4	B092600274	Bolt M4X8	4	
5	213907004	Foot lifting motor assy	1	
6	B092609074	Bolt M4X10	4	
7	234131000	Switch assm	1	
8	S150220069	Screw M3x25	4	
9	S120501001	Nut M3	4	
10	B085070874	Washer 3	4	
11	234132000	Detector for application feeding	1	
13	213631000	Tension release solenoid assy	1	
14	B093600208	Bolt M4x8	2	
15	B085060874	Washer, Plain 4	2	
16	S150630002	Washer, Spring 4	2	
17	213701000	Thread trimmer solenoid assy	1	
18	B093600208	Bolt M4x8	2	
19	B085060874	Washer, Plain 4	2	
20	S150630002	Washer, Spring 4	2	
21	213809000	Safety switch assy	1	
22	B0F6709605	Screws M3x14DA	2	
23	234130010	Grounding line	1	
24	213000021	Cord holder (M)	3	
25	B0F5609004	Screws M4x10DB	4	
26	213907001	Main shaft motor assy	1	
27	S150220018	Screw M5x20	4	
28	198410000	Lamp	1	

14. Accessories

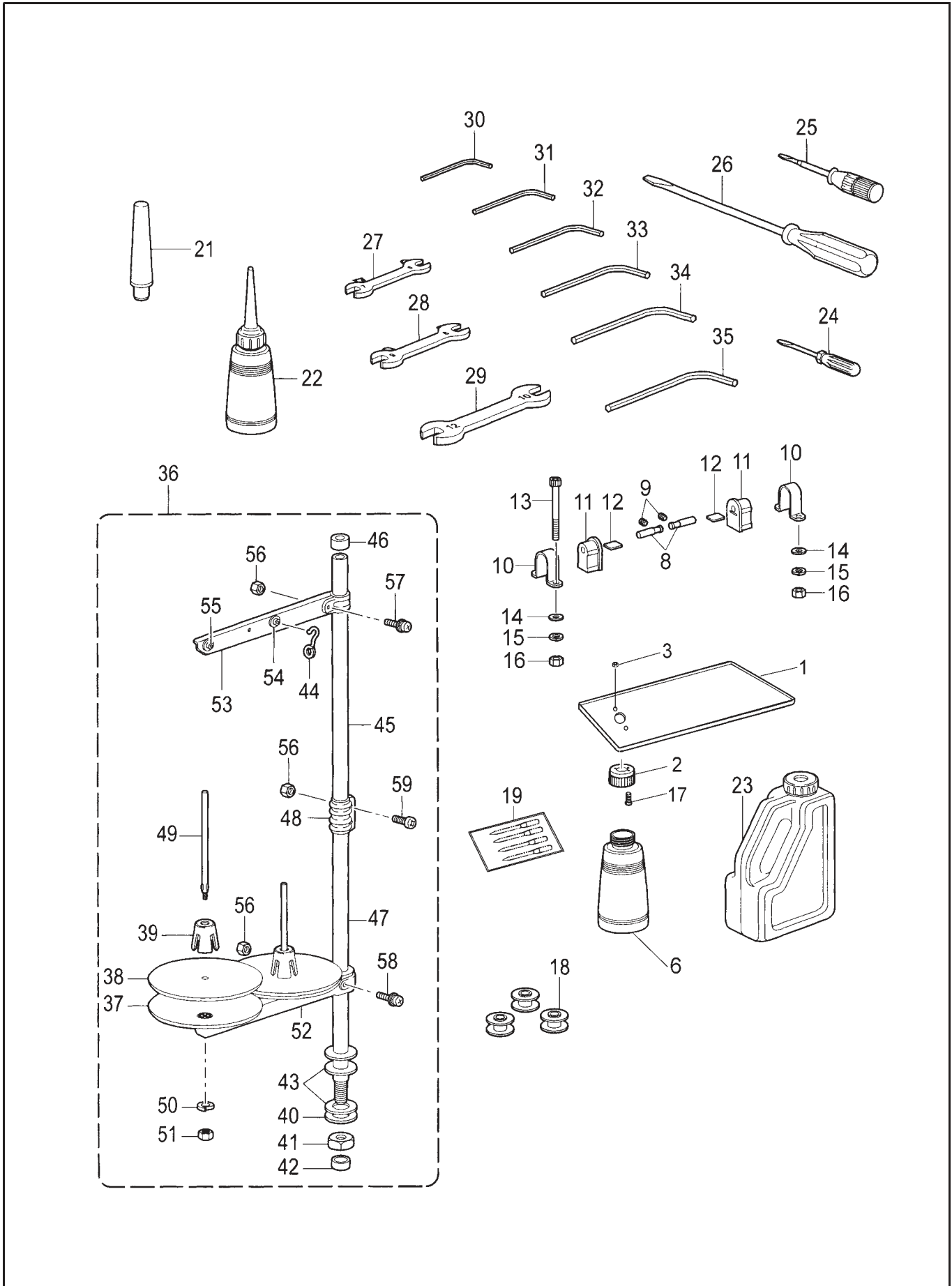

14. Accessories

No.	Ref.No.	Description	Qt.	Note
1	234F02000	Oil pan assy	1	
2	B956643009	Oiler cap	1	
3	S120501001	Nut M3	2	
6	B996624008	Oiler	1	
8	BXF7726009	Pin	2	
9	B098040474	Screw M6x6	2	
10	BXF7725009	Hinge holder	2	
11	BXF7715009	Rubber cushion	2	
12	BXF7718009	Spacer	2	
13	J03840718	Bolt M6x75	4	
14	B085040774	Washer, Plain 6	4	
15	B082040864	Washer, Spring 2-6	4	
16	B089040904	Nut M6	4	
17	S150220022	Screw M3x10	2	
18	B951497059	Bobbin	3	
19	※	Needle assy	1	
21	BXF7720009	Head rest	1	
22	B996627008	Oiler assy	1	
23	BX55447009	Oil tank assy	1	
24	W050102048	Screw-driver 1.9 X52	1	
25	W050102063	Screw-driver 3.4 X70	1	
26	W050102050	Screw-driver 5.5X190	1	
27	B903331009	Wrench 6X7	1	
28	B900223009	Wrench 8X9	1	
29	B903320009	Wrench 10X12	1	
30	W050102033	Hexagonal wrench 1.5	1	
31	W050102034	Hexagonal wrench 2	1	
32	W050102040	Hexagonal wrench 2.5	1	
33	W050102035	Hexagonal wrench 3	1	
34	W050102036	Hexagonal wrench 4	1	
35	W050102037	Hexagonal wrench 5	1	
36	BX08347608	Cotton stand assy	1	
37	BX59827009	Spool stand base	2	
38	B950928000	Spool mat	2	
39	BX59828909	Spool cushion	2	
40	B950804008	Washer, Plain 16	1	
41	BX72462009	Nut	1	
42	B950936000	Column cap	1	
43	BX09005000	Rubber washer	2	
44	BX08363909	Spring	1	
45	B950938007	Column pipe	1	
46	B950936000	Column cap	1	
47	B954998007	Column pipe	1	
48	B950937007	Column joint	1	
49	B950931008	Spool shaft	2	
50	B082050864	Washer, Spring 2-5	2	
51	B089500904	Nut, M5	2	
52	BX08332008	Spool holder	1	
53	BX08323008	Thread hanger	1	
54	B950927000	Thread hanger base	2	
55	B968110009	Thread bush	2	
56	B089500904	Nut M5	4	
57	BX73072009	Screw M5X14	1	
58	BX73073009	Screw M5X32	1	
59	B048509604	Screw M5X14	2	

14. Accessories

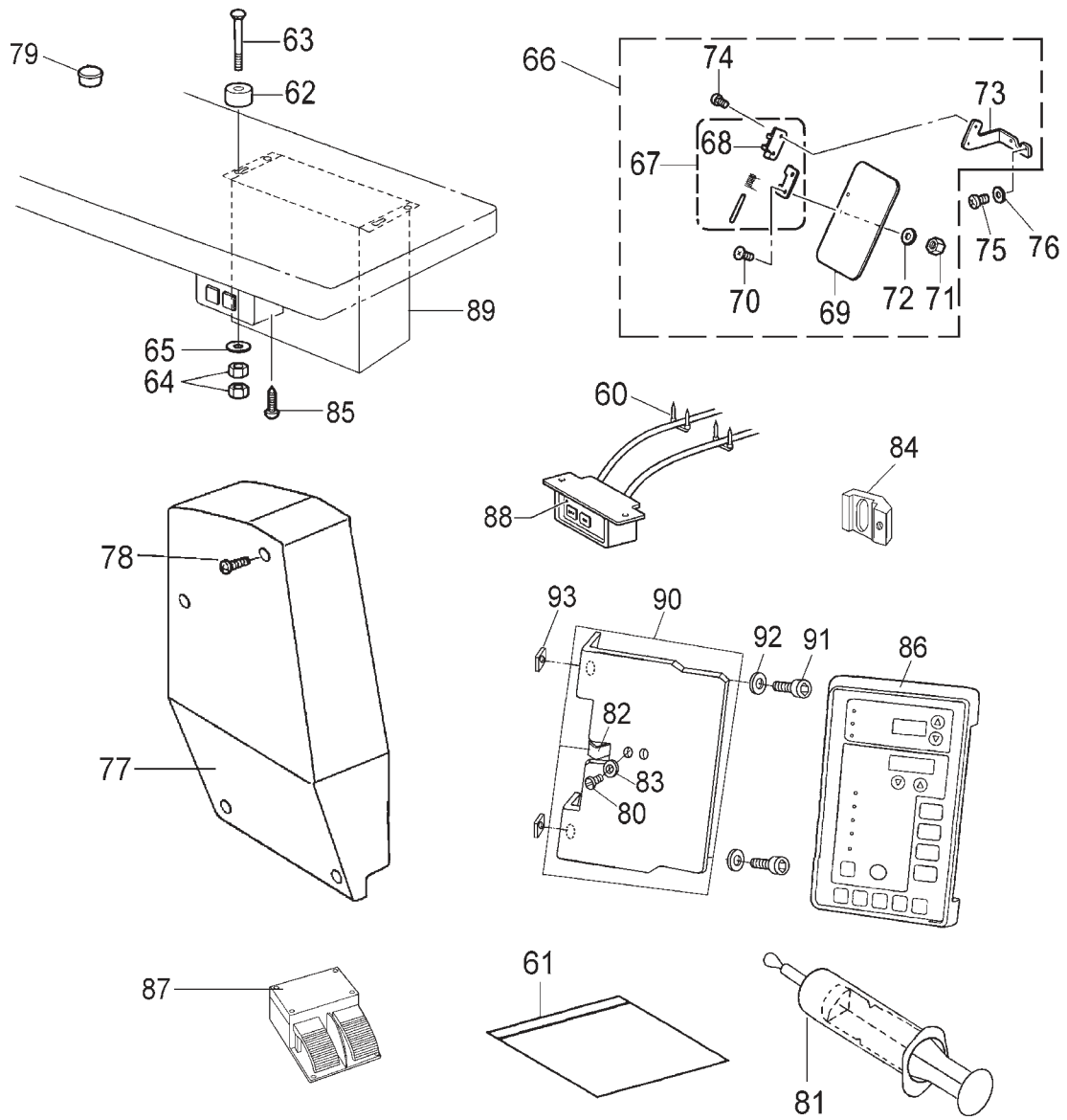

14. Accessories

No.	Ref.No.	Description	Qt.	Note
60	B800910009	Staple	7	
61	B988119009	Accessory bag	1	
62	BX54728000	Rubber washer	4	
63	S150220068	Bolt M6X55	4	
64	B089040904	Nut M6	8	
65	B085040774	Washer, Plain 6	8	
66	213901000	Eye guard assy	1	
67	BX66627009	Hinge assy	1	
68	BX73491009	Eye guard assy	1	
69	BX66625009	Eye guard	1	
70	B049700294	Screw M3X8	2	
71	B089700904	Nut M3	2	
72	B084070874	Washer, Plain 3	2	
73	BXF6906009	Eye guard holder	1	
74	B048700504	Screw M3X5	2	
75	B048600494	Screw M4X6	2	
76	B084060974	Washer, Plain 4	2	
77	213000005	Back cover	1	
78	B048049094	Screw M6X10	4	
79	B906289009	Rubber cap 10.5	4	
80	B048700694	Screw M3x 4	2	
81	WWW8417009	Grease unit	1	
82	213000009	Spring plate	1	
83	B085070874	Washer 3	2	
84	234020026	Joint block	1	
85	S150241013	Wood screw 4x16	2	
86	213907009	Operation panel assy	1	
87	234F01000	Foot switch assy	1	
88	213907012	Power supply switch assy	1	
89	234F03001	Control box	1	
90	213000008	Control box installation board	1	
91	B092049874	Bolt M6x12	2	
92	B085040874	Washer, Plain 6	2	
93	213000010	Rubber cushion	2	

Index

Code	Page	No.	Code	Page	No.	Code	Page	No.	Code	Page	No.
022700015	6	31	234020007	6	8	234031004	10	57	B040600594	22	6
022750001	6	49	234020008	6	9	234031005	10	59	B040600594	26	15
022750002	6	52	234020009	6	10	234031006	10	65	B048040294	16	3
023403012	8	38	234020010	6	11	234031007	10	66	B048040294	16	9
198410000	28	28	234020011	6	12	234031008	10	67	B048040294	16	28
213000003	2	7	234020012	6	16	234031009	10	75	B048049094	2	6
213000004	2	5	234020013	6	17	234040001	12	3	B048049094	12	40
213000005	32	77	234020015	6	18	234051000	14	19	B048049094	20	35
213000008	32	90	234020016	6	19	234080001	20	36	B048049094	32	78
213000009	32	82	234020017	6	23	234090001	24	50	B048430698	18	31
213000010	32	93	234020018	6	6	234090002	24	52	B048500294	2	30
213000011	4	36	234020019	6	15	234092000	24	67	B048500494	18	2
213000012	4	38	234020020	6	14	234100001	26	1	B048500494	18	4
213000021	28	24	234020021	6	13	234100002	26	2	B048500494	18	6
213100006	4	34	234020022	6	20	234100003	26	3	B048500494	20	29
213101001	4	12	234020023	6	21	234100004	26	16	B048509094	2	9
213102000	4	17	234020024	6	22	234100005	26	17	B048509094	2	28
213300001	12	36	234020025	6	45	234100006	26	5	B048509604	30	59
213420002	14	34	234020026	6	53	234101000	26	6	B048600294	2	29
213501000	16	12	234020026	32	84	234130005	26	9	B048600294	22	4
213631000	28	13	234021000	6	24	234130010	28	23	B048600494	16	7
213700005	22	1	234021001	6	25	234131000	28	7	B048600494	16	11
213701000	28	17	234030001	8	5	234132000	28	11	B048600494	26	12
213809000	28	21	234030002	8	2	※	30	19	B048600494	32	75
213901000	32	66	234030003	8	20	※	4	30	B048609004	2	20
213907001	28	26	234030004	8	24	※	14	40	B048609004	26	7
213907002	28	1	234030005	8	9	※	14	48	B048609894	20	13
213907003	28	3	234030006	10	76	※	18	9	B048700494	14	25
213907004	28	5	234030007	10	83	※	18	14	B048700504	32	74
213907009	32	86	234030008	8	25	※	24	61	B048700694	2	17
213907012	32	88	234030009	8	22	036E02002	2	22	B048700694	4	5
234000001	2	25	234030010	8	28	234F01000	32	87	B048700694	24	58
234000002	2	26	234030011	8	39	234F02000	30	1	B048700694	32	80
234000003	2	27	234030013	8	40	234F03001	32	89	B048750494	20	8
234020001	6	1	234030014	8	46	B006700597	2	12	B049700294	32	70
234020002	6	2	234030015	8	45	B029007430	14	18	B062020768	6	40
234020003	6	3	234031000	10	51	B030402200	8	17	B062020768	12	11
234020004	6	4	234031001	10	52	B030414200	12	18	B062020768	12	24
234020005	6	5	234031002	10	53	B030422250	12	33	B062020968	8	18
234020006	6	7	234031003	10	56	B039079260	10	81	B062030768	14	37

Code	Page	No.	Code	Page	No.	Code	Page	No.	Code	Page	No.
B062030768	22	36	B089040904	24	43	B098040474	12	22	B900608006	18	17
B062040764	10	61	B089040904	30	16	B098040474	12	28	B900609089	20	31
B062040768	8	12	B089040904	32	64	B098040474	14	9	B900740007	24	62
B062040768	12	30	B089500904	30	51	B098040474	14	16	B900974009	18	20
B062050768	20	10	B089500904	30	56	B098040474	14	35	B901871008	2	15
B062050768	20	19	B089600704	26	4	B098040474	18	28	B903320009	30	29
B062060768	22	18	B089700904	32	71	B098040474	22	37	B903331009	30	27
B062060768	26	7	B092047074	8	6	B098040474	24	49	B906289009	2	3
B063408068	12	4	B092047574	8	34	B098040474	30	9	B906289009	32	79
B063709068	12	27	B092049474	10	79	B098040574	10	63	B906661009	2	8
B082040864	30	15	B092049874	8	31	B098040574	12	32	B908470009	12	8
B082050864	30	50	B092049874	8	36	B098040574	12	38	B929018009	4	32
B084060974	32	76	B092049874	10	50	B098040574	14	6	B950804008	30	40
B084070874	32	72	B092049874	10	85	B098500574	4	21	B950927000	30	54
B084070974	14	24	B092049874	12	35	B098500574	4	31	B950928000	30	38
B085040774	30	14	B092049874	32	91	B098500574	6	37	B950931008	30	49
B085040774	32	65	B092500274	10	69	B098500574	6	41	B950936000	30	42
B085040874	8	32	B092509474	4	3	B098500574	6	44	B950936000	30	46
B085040874	8	37	B092509878	6	28	B098500574	8	4	B950937007	30	48
B085040874	10	49	B092509878	8	42	B098500574	10	64	B950938007	30	45
B085040874	10	78	B092509878	10	54	B098500574	12	12	B951205009	18	15
B085040874	10	86	B092509878	14	39	B098500574	12	20	B951490609	14	41
B085040874	32	92	B092600274	10	84	B098500574	12	25	B951497059	14	45
B085040974	20	24	B092600274	28	4	B098500574	14	11	B951497059	30	18
B085050874	10	55	B092609074	8	21	B098500574	14	47	B951498009	14	44
B085050874	26	8	B092609074	28	2	B098500574	20	3	B951624009	20	9
B085060874	26	8	B092609074	28	6	B098500574	20	34	B951886009	18	23
B085060874	26	13	B092609474	4	25	B098600674	6	47	B952229009	18	27
B085060874	26	18	B093600208	28	14	B098600674	10	82	B954998007	30	47
B085060874	26	5	B093600208	28	18	B098600674	14	12	B956511000	22	12
B085060874	28	15	B093609095	26	3	B098600674	20	17	B956511000	26	2
B085060874	28	19	B096330488	4	33	B098600674	20	23	B956514000	6	50
B085070874	2	18	B098040474	4	9	B098600674	22	11	B956514000	22	23
B085070874	24	60	B098040474	6	33	B098600674	22	17	B956643009	30	2
B085070874	28	10	B098040474	8	8	B098700774	4	19	B956769009	14	43
B085070874	32	83	B098040474	8	13	B0F5609004	28	25	B956771909	14	42
B089040704	22	28	B098040474	8	15	B0F6709605	28	22	B957050000	14	26
B089040704	24	45	B098040474	8	19	B800910009	32	60	B957050000	16	30
B089040904	22	26	B098040474	8	27	B879039009	22	20	B957053909	8	29
B089040904	22	30	B098040474	12	13	B900223009	30	28	B957061009	18	7

Code	Page	No.	Code	Page	No.	Code	Page	No.	Code	Page	No.
B957188009	16	17	BX08332008	30	52	BX87459009	4	14	BXF7572009	24	63
B957514009	22	35	BX08347608	30	36	BX87459009	6	46	BXF7576009	8	26
B957530009	10	72	BX08363909	30	44	BX87459009	14	8	BXF7577009	8	3
B957542009	10	71	BX08458009	22	13	BX87459009	20	37	BXF7582009	4	24
B957997009	8	11	BX08681809	14	20	BX87459009	22	2	BXF7611009	4	2
B958173009	20	7	BX09005000	30	43	BX87459009	22	19	BXF7613009	4	16
B958174009	20	6	BX09414009	6	27	BX87692008	20	15	BXF7622009	4	23
B958226009	18	30	BX50581000	16	14	BX90672009	20	18	BXF7626009	4	4
B958227000	18	29	BX51224009	14	32	BX90842009	20	26	BXF7650009	4	4
B958232009	4	35	BX54233000	16	19	BX98411000	18	10	BXF7659009	6	38
B958322000	10	73	BX54728000	32	62	BX98669009	18	13	BXF7661009	6	35
B958366009	12	7	BX55447009	30	23	BX98669009	20	33	BXF7662009	6	34
B958426909	14	23	BX59827009	30	37	BXF4712009	24	56	BXF7664009	6	42
B960603009	6	51	BX59828909	30	39	BXF4713009	24	56	BXF7665009	12	34
B960718001	2	1	BX65261000	16	16	BXF6038009	12	39	BXF7666009	12	29
B960718001	2	4	BX66625009	32	69	BXF6042909	14	4	BXF7667009	12	26
B964020000	16	24	BX66627009	32	67	BXF6564009	22	31	BXF7668009	12	21
B964756008	10	68	BX71410089	22	9	BXF6646009	2	10	BXF7669009	6	36
B964756009	8	47	BX72462009	30	41	BXF6648009	16	27	BXF7669009	6	43
B964756009	24	64	BX72761009	2	21	BXF6777009	18	3	BXF7669009	12	19
B965465009	4	22	BX73072009	30	57	BXF6888009	16	29	BXF7670009	12	2
B965664009	18	16	BX73073009	30	58	BXF6906009	32	73	BXF7671009	12	17
B965664009	18	22	BX73491009	32	68	BXF6910009	14	14	BXF7672009	12	16
B965664009	20	30	BX76098000	16	20	BXF6913009	8	14	BXF7673009	12	15
B966652009	4	27	BX77490989	26	14	BXF6920009	4	8	BXF7674009	12	14
B967439000	16	21	BX78645009	22	25	BXF6921009	14	14	BXF7675009	12	9
B968110009	30	55	BX78645009	24	42	BXF6922009	14	14	BXF7676009	12	6
B969382009	6	30	BX78648009	22	27	BXF6923009	14	14	BXF7681009	12	1
B980662009	20	22	BX78648009	24	44	BXF6931009	4	7	BXF7682009	10	80
B988119009	32	61	BX79078009	18	12	BXF6939009	20	5	BXF7683009	10	70
B990743009	4	18	BX79078009	20	32	BXF6964009	18	21	BXF7684009	10	58
B990743009	10	60	BX80754009	6	39	BXF7302009	8	33	BXF7701009	22	14
B993176009	2	2	BX80754009	12	10	BXF7303009	12	37	BXF7703009	22	10
B994111009	4	32-2	BX80754009	12	23	BXF7452009	24	57	BXF7704009	22	8
B994336009	4	32-1	BX82066009	2	23	BXF7454009	24	53	BXF7705009	22	7
B996624008	30	6	BX82695000	16	15	BXF7475009	18	25	BXF7706009	22	3
B996627008	30	22	BX85635009	22	29	BXF7506809	16	6	BXF7707009	22	5
BX003305009	24	55	BX85661889	26	11	BXF7507809	16	5	BXF7715009	30	11
BX03777009	16	23	BX85790909	24	59	BXF7572009	6	32	BXF7718009	30	12
BX08323008	30	53	BX85875009	4	15	BXF7572009	8	23	BXF7720009	30	21

Code	Page	No.	Code	Page	No.	Code	Page	No.	Code	Page	No.
BXF7725009	30	10	BXF7816009	20	14	BXF7882009	14	3	S8A3101005	26	10
BXF7726009	30	8	BXF7817009	20	11	BXF7883009	14	2	T2D280203	4	37
BXF7728009	8	35	BXF7818009	4	4	BXF7884009	14	1	W050102033	30	30
BXF7729009	8	30	BXF7819009	20	4	BXF7886009	4	29	W050102034	30	31
BXF7730009	8	16	BXF7820009	16	26	BXF7887009	4	28	W050102035	30	33
BXF7731009	16	13	BXF7821009	20	1	BXF7888009	4	26	W050102036	30	34
BXF7742009	8	10	BXF7823009	16	22	BXF8152009	4	20	W050102037	30	35
BXF7747009	8	1	BXF7826009	14	38	BXF9122009	20	25	W050102040	30	32
BXF7750009	26	11	BXF7827009	14	46	BXF9126009	20	12	W050102048	30	24
BXF7754009	24	51	BXF7828009	16	8	BXF9708009	16	18	W050102050	30	26
BXF7761009	26	10	BXF7831009	16	4	BXF9881909	18	18	W050102063	30	25
BXF7762009	26	9	BXF7832009	14	36	BXF9931008	10	74	WWW8417009	32	81
BXF7763009	26	6	BXF7834009	14	33	BXF9939009	6	48			
BXF7765009	26	1	BXF7835009	14	31	BXH5320009	8	7			
BXF7776009	24	56	BXF7836909	14	29	J01540020	26	4			
BXF7777009	24	54	BXF7837009	14	15	J03840718	30	13			
BXF7780009	22	38	BXF7843009	4	4	J038440551	10	77			
BXF7784009	24	48	BXF7844009	2	16	S120501001	28	9			
BXF7785009	24	47	BXF7845009	2	14	S120501001	30	3			
BXF7786009	24	46	BXF7846009	2	13	S120501005	6	29			
BXF7787009	24	41	BXF7847009	2	11	S150217009	14	21			
BXF7789009	22	39	BXF7850009	18	1	S150217009	14	28			
BXF7790009	22	15	BXF7852009	18	26	S150217009	14	30			
BXF7791009	22	34	BXF7854009	18	19	S150220001	24	65			
BXF7792009	22	33	BXF7855009	18	11	S150220007	8	43			
BXF7793009	22	32	BXF7856009	18	8	S150220007	10	48			
BXF7795009	22	24	BXF7858009	18	5	S150220007	24	40			
BXF7797009	22	22	BXF7861009	16	10	S150220018	28	27			
BXF7798009	22	21	BXF7864009	16	25	S150220022	30	17			
BXF7799009	22	16	BXF7865009	16	2	S150220068	32	63			
BXF7800909	2	19	BXF7866009	16	1	S150220069	28	8			
BXF7804009	4	6	BXF7868909	14	27	S150220078	8	44			
BXF7804009	4	10	BXF7869009	14	22	S150241013	32	85			
BXF7809009	4	1	BXF7872909	14	17	S150435018	2	24			
BXF7810009	20	2	BXF7873009	14	13	S150630002	28	16			
BXF7811009	20	28	BXF7876009	14	10	S150630002	28	20			
BXF7812009	20	27	BXF7877009	14	7	S150632004	24	66			
BXF7813009	20	21	BXF7879009	10	62	S150866006	4	13			
BXF7814009	20	20	BXF7879009	12	31	S150866037	4	11			
BXF7815009	20	16	BXF7879009	14	5	S150866069	6	26			

● Besides adjusting stitch, please laypeople don't debug or maintain.

● Parts are subject to changes in design without prior notice.

XI'AN TYPICAL INDUSTRIES CO.,LTD.

Add: No.355 Taibai South Road,
Xi'an, P.R.China-710068
Tel :+86-29-88279091 88279150
Fax :+86-29-88249715 88245215
E-mail:typical@chinatypical.com
Http:www.chinatypical.com
Http:www.globalsources.com

2010.03.20 ①